

# Festoon Systems for I-Beams

Program 0365/0370/0375

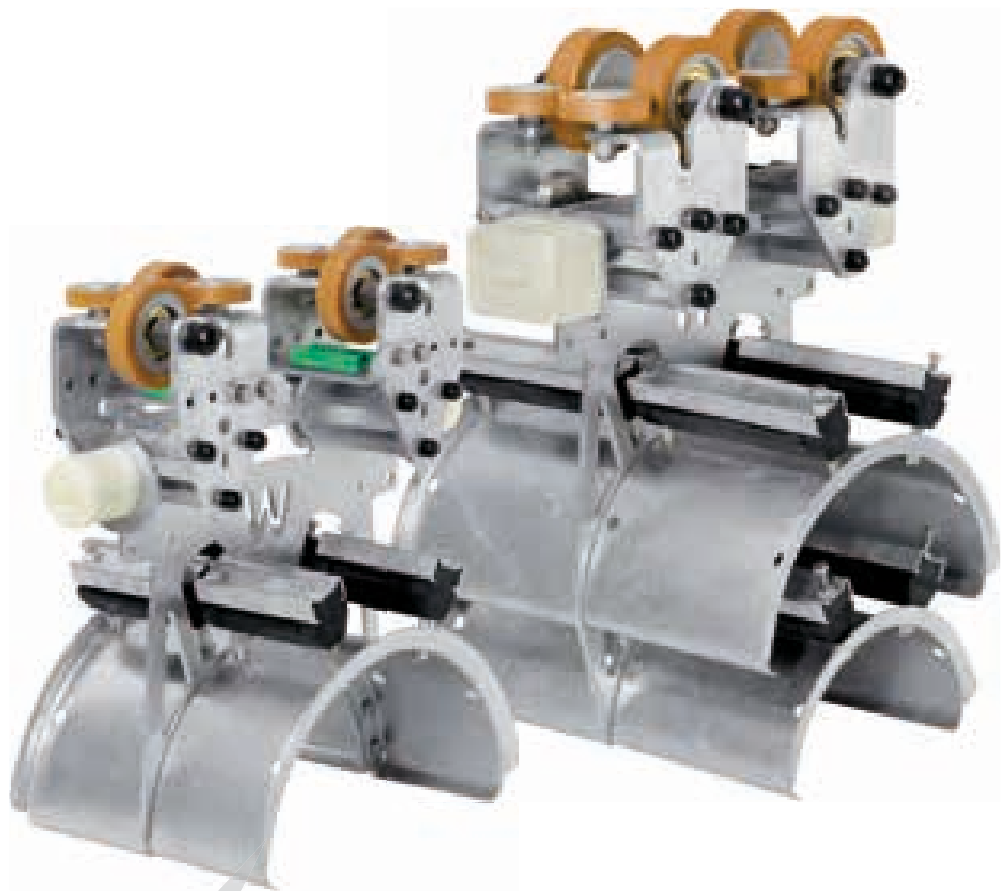



# Contents

---

## System Arrangement

Festoon System for Flat and Round Cables	2
System Components	2

---

## Cable Trolleys for Round Cables Program 0365

Single Layer Cable Trolleys with Main Rollers $\varnothing 112$ mm / $\varnothing 125$ mm	3
Selection of Cable Trolleys and Towing Trolleys	4
Selection of End Clamps and Towing Clamps	5
Selection of Running Gear	5

---

## Cable Trolleys for Flat Cables Program 0370

Dual Layer Cable Trolleys for Flat Cables with Main Rollers $\varnothing 125$ mm / $\varnothing 160$ mm	7
Selection of Cable Trolleys and Towing Trolleys	8
Selection of End Clamps and Towing Clamps	9
Selection of Running Gear	9

---

## Cable Trolleys for Round Cables Program 0375

Dual Layer Cable Trolleys with Main Rollers $\varnothing 125$ mm / $\varnothing 160$ mm	11
Selection of Cable Trolleys and Towing Trolleys	12
Selection of End Clamps and Towing Clamps	13
Selection of Running Gear	13

---

## Accessories for Festoon Systems Program 0365, 0370 and 0375

Towing Ropes	15
Damping Devices	15
Cable Organizers for Cable Loops	16
Additional Clamping Piece for Round Cable Clamps	16
Round Cable Clamps	17
Spacers	18
Flat Cable Clamps	18
Lifting Device	19

---

## Wear Parts for Cable Trolleys Program 0365, 0370 and 0375

Replacement Rollers for Running Gear Types HMG and HMP	20
Shock Cords	20
Cellular Buffer 080x080	21
Cellular Buffer 150x110x080	21
Buffer Unit	21

---

## Spare Parts for Cable Trolleys 0365, 0370 and 0375

Cable Supports Complete	22
Clamping Bars Complete	22
Side Shields Complete	23
Running Gear Complete	24

---

## Technical Appendix Specification of Preference Range I-Beams

Dimensions of the Standard I-Beams for Program 0365 Parallel Flange	28
Dimensions of the Standard I-Beams for Program 0365 Tapered Flange	28
Dimensions of the Standard I-Beams for Program 0370 and 0375 Parallel Flange	28

# System Arrangement

## Festoon System for Flat and Round Cables

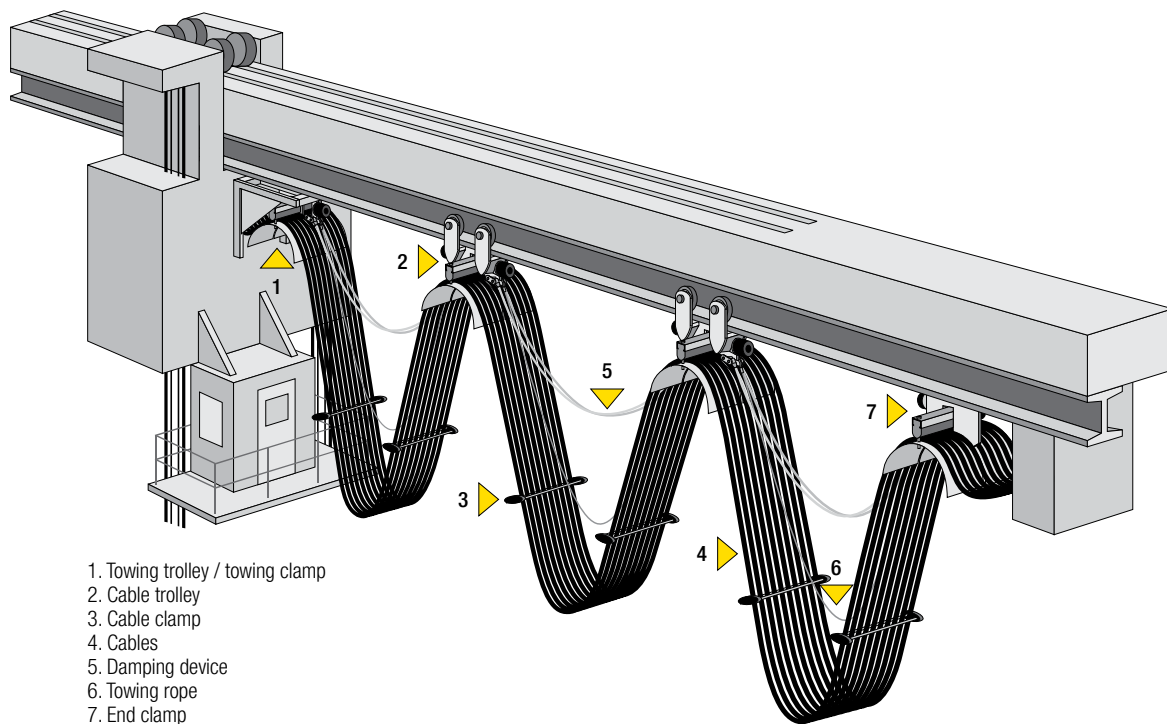

1. Towing trolley / towing clamp
2. Cable trolley
3. Cable clamp
4. Cables
5. Damping device
6. Towing rope
7. End clamp

## System Components

A festoon system consists of the following components:

- 1 x end clamp
- X x cable trolley
- 1 x towing clamp or alternatively 1 x towing trolley
- Cable trolleys and towing trolleys require a running gear, which must be selected in addition to the trolley under part
- Cable trolleys and towing trolleys are set to fit the exact track beam, in all cases the track beam must be specified
- The system components can be equipped with one additional cable support depending on the program.

To ensure optimum operation of the system, depending upon the application, various accessories must be added, e.g. flat or round cable clamps, towing ropes or damping devices.

The Order No. of the system components is determined by the combination of the following single sub-assemblies:

	Underpart with Cable Support	Running Gear	Track Beam Designation
Cable Trolley	•	•	•
Towing Trolley Underpart	•	•	•
Towing Clamp	•	-	-
End Clamp	•	-	-

For order no. see the respective catalog pages of the programs.

The system components are completely assembled prior to delivery, cable trolleys and towing trolleys are adjusted to the respective track beam.

# Cable Trolleys for Round Cables Program 0365

Single Layer Cable Trolleys with with Main Rollers  $\varnothing$  112 mm /  $\varnothing$  125 mm



## Technical details

Cable supports	bolted to the center plate, lateral-loading and reinforced
Clamping bar	V-clamping (divided)
Buffers	double-sided cellular buffer
Travel speed max. <sup>1)</sup>	300 m/min <sup>2)</sup>
Load capacity max. <sup>1)</sup>	350 kg
Cable trolley underpart and running gear	hot-dipped galvanized steel
Fasteners	stainless steel
Temperature range	-30°C to +50°C

<sup>1)</sup> depending on roller size/ roller material

<sup>2)</sup> together with motorized trolleys

## Ordering Example

Order No. 036523-93 - 745 - 0124

A cable trolley underpart with the following dimensions shall be used:

- Support diameter:  $d_a = 460$  mm
- Clamping width:  $b_2 = 125$  mm;
- Clamping height:  $s = 46$  mm

Order No. 036523-93 (chosen from catalog page 4)

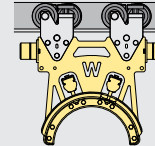

The following running gear has been chosen:

Type HMG

- Cylindrical main rollers  $\varnothing$  112 mm with Vulkollan bandage
- With horizontal guide rollers with Vulkollan bandage
- With anti-lift rollers made of stainless steel

Order No. 745 (chosen from catalog page 5)

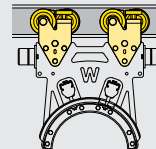

The following track beam has been chosen:

- IPE 240
- I-beam code 0124 (chosen from catalog page 5)

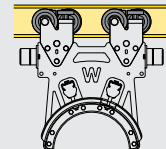

The order no. of the appropriate towing clamp is:

036543-93

As an alternative to the towing clamp a towing trolley can be used.

The order no. of the appropriate towing trolley is:

036533-93-745-0124

The order no. of the appropriate end clamp is:

036513-93

The order no. of the appropriate towing trolley for the connection to the catenary trolley is:

036553-93-745-0124

For calculation and selection please refer to the Engineering Guideline KAT0300-0101.



# Cable Trolleys for Round Cables Program 0365

## Selection of End Clamps and Towing Clamps

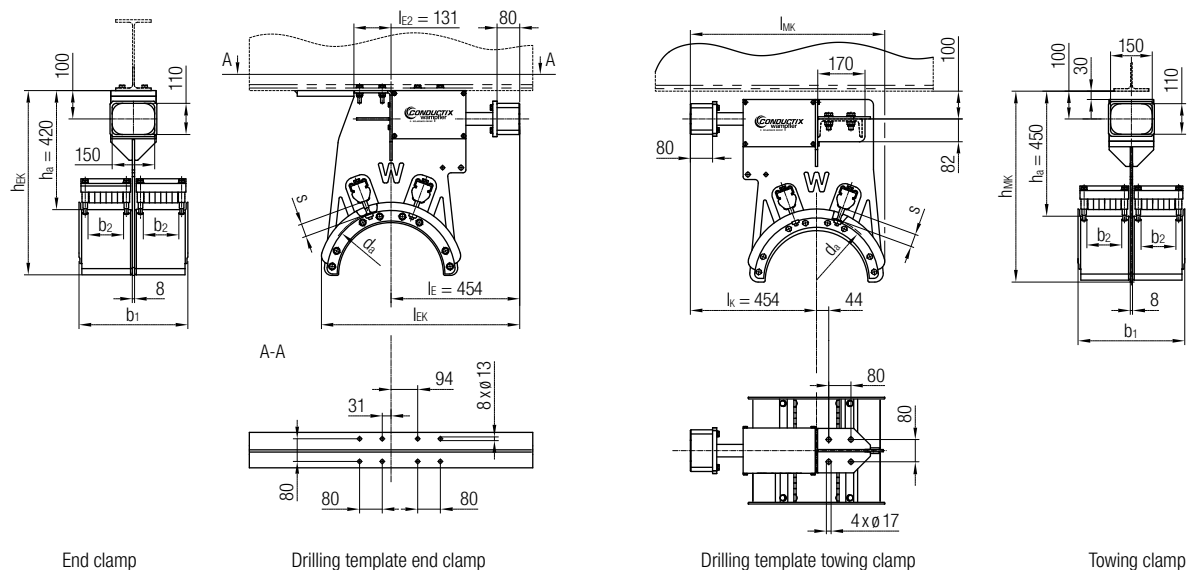

End Clamp Complete Order No.	[kg]	Towing Clamp Complete Order No.	[kg]	$d_a$ [mm]	$l_{EK}/l_{MK}$ [mm]	$b_1$ [mm]	$b_2$ [mm]	$s$ [mm]	$h_{EK}/h_{MK}$ [mm]
036513-83	49	036543-83	49	360	665	384	125	36	643
036513-86	52	036543-86	52			532	200		
036513-88	54	036543-88	54			632	250		
036513-93	53	036543-93	53	460	700	384	125	46	687
036513-96	57	036543-96	57			532	200		
036513-98	60	036543-98	60			632	250		

## Selection of Running Gear

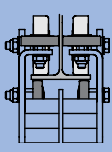
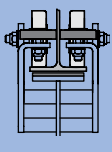
Running Gear	Order No.	Main Roller $\phi d$ [mm]	Material Bandage	Weight approx. [kg]	Parallel-Flange	Preference Range I-Beam Code	I-Beams Tapered-Flange	I-Beam Code
 <p><b>Type HMG</b> with cylindrical main rollers, horizontal guide rollers at the beam center web and anti-lift rollers</p>	745	112	Vulkollan	20	IPE 240	0124	INP 220	0022
	775	112	Adiprene	20	G 3192 250 x 125 x 6 x 9		GB 706-65/20a	
	845	125	Vulkollan	22	W 8 x 18		G 3192 200 x 100 x 7 x 10 x 8°	
	875	125	Adiprene	22	S 8 x 18.4			
 <p><b>Type HMP</b> with cylindrical main rollers, horizontal guide rollers at the beam center web and anti-lift plate</p>	749	112	Vulkollan	20	IPE 240	0124	INP 220	0022
	779	112	Adiprene	20	G 3192 250 x 125 x 6 x 9		GB 706-65/20a	
	849	125	Vulkollan	22	W 8 x 18		G 3192 200 x 100 x 7 x 10 x 8°	
	879	125	Adiprene	22	S 8 x 18.4			

### Notes / design

- Main roller  $\phi 112$  mm: anti-lift roller  $\phi 63$  mm made of stainless steel, horizontal guide roller  $\phi 63$  mm with Vulkollan respectively Adiprene bandage
- Main roller  $\phi 125$  mm: anti-lift roller  $\phi 63$  mm made of stainless steel, horizontal guide roller  $\phi 80$  mm with Vulkollan respectively Adiprene bandage
- As an alternative to the anti-lift rollers an anti-lift plate, made of plastic, can be used. (running gear HMP, but not for towing trolley and towing trolley for catenary trolley)
- The rollers are equipped with precision ball bearings and additional sealing disks (2RS1), the ball bearings are lifetime lubricated and therefore maintenance free
- Running gear for other I-beam types or beam sizes on request





# Cable Trolleys for Flat Cables Program 0370

Dual Layer Cable Trolleys for Flat Cables with Main Rollers  $\varnothing$  125 mm /  $\varnothing$  160 mm



## Technical details

Cable supports	bolted to the center plate, lateral-loading and reinforced
Clamping bar	V-clamping (divided)
Buffers	double-sided cellular buffer
Travel speed max. <sup>1)</sup>	210 m/min
Load capacity max. <sup>1)</sup>	350 kg
Cable trolley underpart and running gear	hot-dipped galvanized steel
Fasteners	stainless steel
Temperature range	-30°C bis +50°C

<sup>1)</sup> depending on roller size/ roller material

## Ordering Example

Order No. 037023-8666 - 845 - 0220

A cable trolley underpart with the following dimensions shall be used:

- Support diameter:  $d_a / d_{a2} = 360 / 260$  mm
  - Clamping width:  $b_2 = 200$  mm;
  - Clamping height:  $s / s_2 = 85 / 40$  mm
- Order No. 037023- 8666 (chosen from catalog page 8)

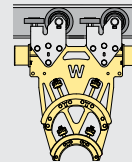

The following running gear has been chosen:  
Type HMG

- Cylindrical main rollers  $\varnothing$  125 mm with Vulkollan bandage
  - With horizontal guide rollers with Vulkollan bandage
  - With anti-lift rollers made of stainless steel
- Order No. 845 (chosen from catalog page 9)

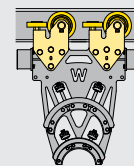

The following track beam has been chosen:

- IPB 200
- I-beam code 0220 (chosen from catalog page 9)

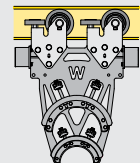

The order no. of the appropriate towing clamp is:

037043-8666

As an alternative to the towing clamp a towing trolley can be used.

The order no. of the appropriate towing trolley is:

037033-8666-845-0220

The order no. of the appropriate end clamp is:

037013-8666

For calculation and selection please refer to the Engineering Guideline KAT0300-0101.

# Cable Trolleys for Flat Cables Program 0370

## Selection of Cable Trolleys and Towing Trolleys

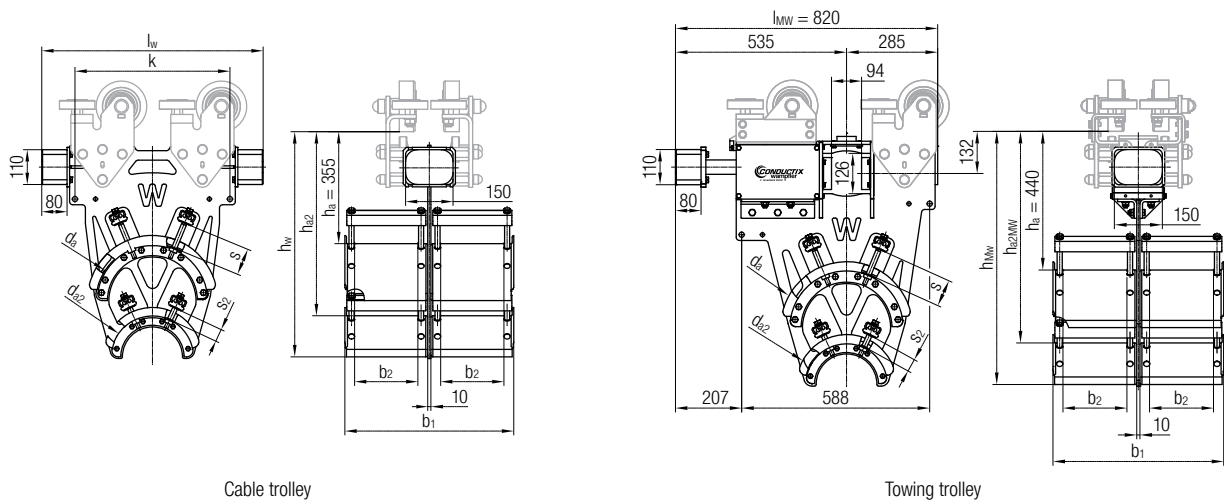

Cable trolley

Towing trolley

Cable Trolley Underpart without Running Gear Order No.	[kg]	Towing trolley- without Running Gear Order No.	[kg]	$d_a / d_{a2}$	$l_w$	$b_1$	$b_2$	$s / s_2$	$k$	$h_{a2}$	$h_w$	$h_{a2MW}$	$h_{MW}$
				[mm]	[mm]	[mm]	[mm]	[mm]	[mm]	[mm]	[mm]	[mm]	[mm]
037023-8363	38	037033-8363	64	360/260	700	386	125	85/40	440	528	716	613	803
037023-8666	45	037033-8666	71			534	200						
037023-8868	50	037033-8868	76			634	250						

### Notes

- The table only refers to the cable trolley or the towing trolley under part
- The running gear must be selected and added. (see page 9 in this catalog)
- The cable trolley is always equipped with an additional support





# Cable Trolleys for Round Cables Program 0375

Dual Layer Cable Trolleys with Main Rollers  $\varnothing$  125 mm /  $\varnothing$  160 mm



## Technical details

Cable supports	bolted to the center plate, lateral-loading and reinforced
Clamping bar	V-clamping (divided)
Buffers	double-sided cellular buffer
Travel speed max. <sup>1)</sup>	300 m/min <sup>2)</sup>
Load capacity max. <sup>1)</sup>	800 kg
Cable trolley underpart and running gear	hot-dipped galvanized steel
Fasteners	stainless steel
Temperature range	-30°C bis +50°C

<sup>1)</sup> depending on roller size/ roller material

<sup>2)</sup> together with motorized trolleys

## Ordering Example

Order No. 037523-9888 - 975 - 0220

A cable trolley underpart with the following dimensions shall be used:

- Support diameter:  $d_a / d_{a2} = 460 / 360$  mm
  - Clamping width:  $b_2 = 250$  mm;
  - Clamping height:  $s / s_2 = 46 / 36$  mm
- Order No. 037523-9888 (chosen from catalog page 12)

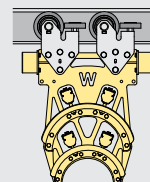

The following running gear has been chosen:

Type HMG

- Cylindrical main rollers  $\varnothing$  160 mm with Vulkollan bandage
- With horizontal guide rollers with Adiprene bandage
- With anti-lift rollers made of stainless steel

Order No. 975 (chosen from catalog page 13)

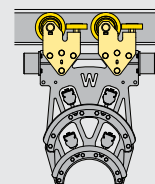

The following track beam has been chosen:

- G3192 200x200x8x12
- I-beam code 0220 (chosen from catalog page 13)

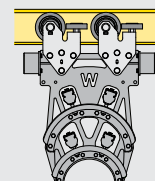

The order no. of the appropriate towing clamp is:

037543-9888

As an alternative to the towing clamp a towing trolley can be used.

The order no. of the appropriate towing trolley is:

037533-9888-975-0220

The order no. of the appropriate end clamp is:

037513-9888

For calculation and selection please refer to the Engineering Guideline KAT0300-0101.

# Cable Trolleys for Round Cables Program 0375

## Selection of Cable Trolleys and Towing Trolleys

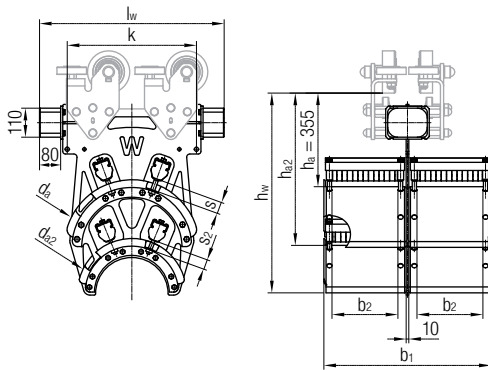

Cable trolley

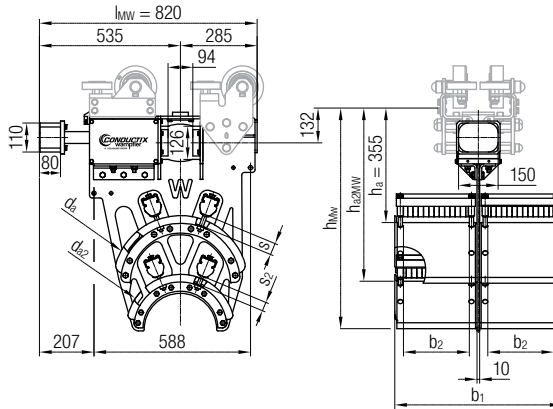

Towing trolley

Cable Trolley Underpart without Running Gear Order No.	[kg]	Towing Trolley- without Running Gear Order No.	[kg]	$d_a / d_{a2}$	$l_w$	$b_1$	$b_2$	$s / s_2$	$k$	$h_{a2}$	$h_w$	$h_{a2MW}$	$h_{MW}$
				[mm]	[mm]	[mm]	[mm]	[mm]	[mm]	[mm]	[mm]	[mm]	[mm]
037523-8363	38	037533-8363	64	360/260	700	386	125	36/26	440	528	716	613	803
037523-8666	45	037533-8666	71			534	200						
037523-8868	50	037533-8868	76			634	250						
037523-8969	66	037533-8969	92			782	320						
037523-9383	47	037533-9383	73	460/360	700	386	125	46/36	490	578	766	663	853
037523-9686	54	037533-9686	80			534	200						
037523-9888	60	037533-9888	86			634	250						
037523-9989	81	037533-9989	107			782	320						

# Cable Trolleys for Round Cables Program 0375

## Selection of End Clamps and Towing Clamps

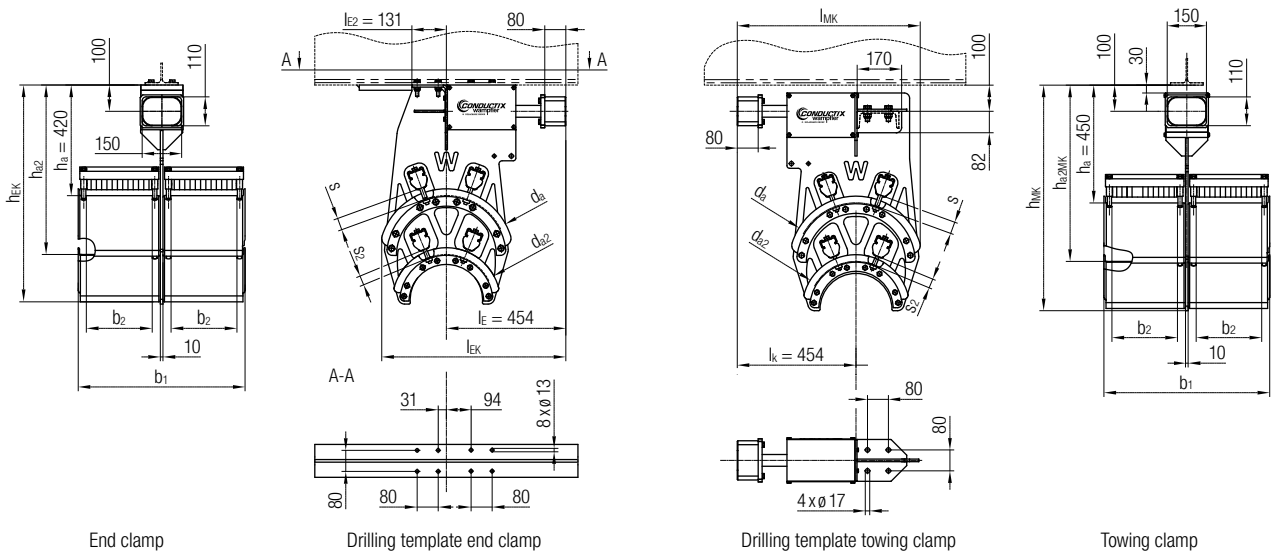

End Clamp Complete Order No.	[kg]	Towing Clamp Complete Order No.	[kg]	$d_E / d_{E2}$	$l_{EK} / l_{MK}$	$b_1$	$b_2$	$s / s_2$	$h_{E2}$	$h_{E2MK}$	$h_{EK}$	$h_{MK}$
				[mm]	[mm]	[mm]	[mm]	[mm]	[mm]	[mm]	[mm]	[mm]
037513-8363	56	037543-8363	56	360/260	665	386	125	36/26	599	624	783	813
037513-8666	63	037543-8666	63			534	200					
037513-8868	68	037543-8868	68			634	250					
037513-8969	84	037543-8969	84			782	320					
037513-9383	65	037543-9383	65	460/360	700	386	125	46/36	644	674	833	863
037513-9686	72	037543-9686	72			534	200					
037513-9888	78	037543-9888	78			634	250					
037513-9989	99	037543-9989	99			782	320					

## Selection of Running Gear

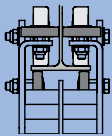
Running Gear		Order No.	Main Roller $\phi d$ [mm]	Main Roller Material Bandage	Weight approx. [kg]	Parallel-Flange	Preference Range I-Beams I-Beam Code	Tapered-Flange	I-Beam Code
 <p><b>Type HMG</b> with cylindrical main rollers, horizontal guide rollers at the beam center web and anti-lift rollers</p>	845	125	Vulkollan	40	IPB 200 G 3192 200x200x8x12 W 8x40	0220			
	875	125	Adiprene	40					
	945	160	Vulkollan	44					
	975	160	Adiprene	44					

### Notes / design

- Main roller  $\phi 125$  mm: anti-lift roller  $\phi 63$  mm made of stainless steel, horizontal guide roller  $\phi 80$  mm with Vulkollan respectively Adiprene bandage
- Main roller  $\phi 160$  mm: anti-lift roller  $\phi 80$  mm made of stainless steel, horizontal guide roller  $\phi 112$  mm with Vulkollan respectively Adiprene bandage
- The rollers are equipped with precision ball bearings and additional sealing disks (2RS1), the ball bearings are lifetime lubricated and therefore maintenance free
- Running gear for other I-beam types or beam sizes on request





# Accessories for Festoon Systems Program 0365, 0370 and 0375

## Towing Ropes

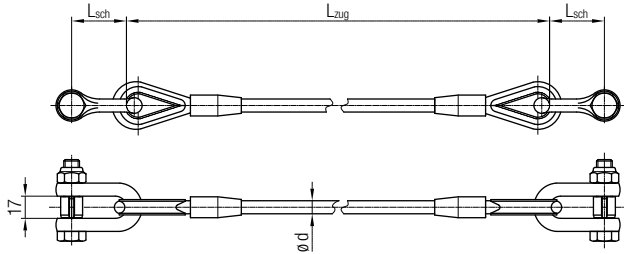

Order No.	ø d [mm]	L <sub>sch</sub> [mm]	Rope	Material Shackle	Fasteners	Program
031963	8/10	42	Galvanized steel	Galvanized steel	Stainless steel	0365 0370 0375
031964	10/12	42	PVC-coated		Seawater resistant aluminum	
031965/2	8/10	48	Stainless steel PVC-coated	Stainless steel	Stainless steel Seawater resistant aluminum	

### Notes

- We recommend the installation of towing ropes for a speed from 50 m/min or a travel distance > 30 m
- The towing ropes are PVC-coated for a better protection against corrosion and to prevent the cables from damage
- For the calculation of the lengths please refer to our Engineering Guideline KAT0300-0101
- In case of order please state the lengths L<sub>zug</sub> of the respective towing ropes

## Damping Devices

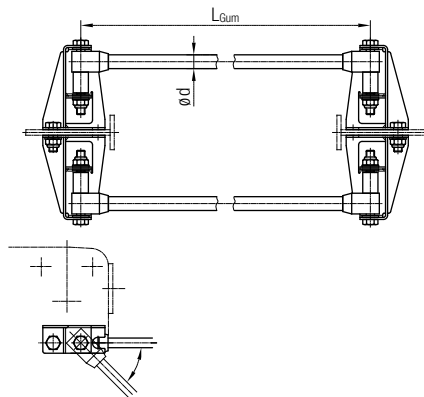

### Technical details

- Shock cord: rubber with plastic plait
- Console: hot-dipped galvanized steel
- Fasteners: stainless steel

Order No.	Number of Shock Cords	ø d [mm]	Program
031976-2	2	20	0365 0370 0375
031977-2	4	20	
031978-2	6	20	
031971	2	28	
031979	4	28	

### Notes

- We recommend the installation of damping devices for high speed and/or short cable loops
- For the calculation of the length please refer to our Engineering Guideline KAT0300-0101
- In case of order please state the length of the respective shock cords L<sub>gum</sub>
- Number and diameter are defined by weight load, cable loop and speed

# Accessories for Festoon Systems Program 0365, 0370 and 0375

## Cable Organizers for Cable Loops

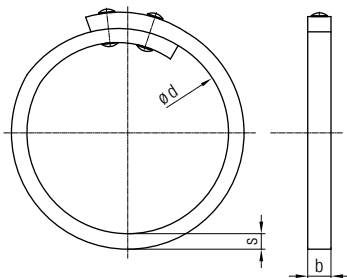

Order No.	ø d [mm]	b [mm]	s [mm]	Material	Fasteners	Weight [kg]
031942-0300	300	30	20	Rubber	Stainless steel	0.90
031942-0500	500	50	20			2.10
031942-0700	700	50	20			2.35

### Note

For cable loops > 4 m, the cable organizer in addition to the at and round cable clamps prevents an expansion of the cables at the lower section of the cable loop.

## Additional Clamping Piece for Round Cable Clamps

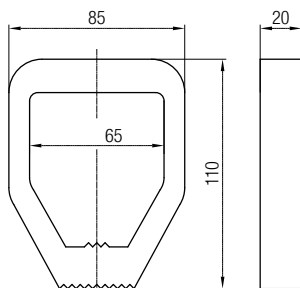

Order No. 031899-065x020/514

### Technical details

- Material: rubber
- Weight: 0.08 kg
- For Program: 0365 / 0370 / 0375

### Note

Differences in diameter between adjacent cables of more than 15 mm require additional clamping pieces for a tight clamping.

# Accessories for Festoon Systems Program 0365, 0370 and 0375

## Round Cable Clamps

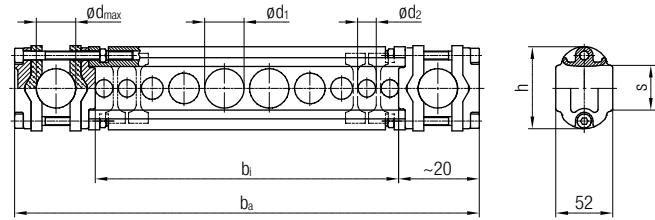

### Technical details

- Clamping: aluminum/rubber
- Guiding profile: aluminum
- Fasteners: stainless steel

Order No.	$\varnothing d_{max}$ [mm]	$b_1$ [mm]	$b_a$ [mm]	$h$ [mm]	$s$ [mm]	$\Sigma d^{1)}$ [mm]	Weight [kg]
031941-026x100/400	26	100	236	64	30	34	0.95
031941-026x150/400		150	286				1.07
031941-026x200/400		200	336				1.09
031941-026x250/400		250	386				1.31
031941-026x300/400		300	436				1.45
031941-026x350/400		350	486				1.57
031941-026x400/400		400	536				1.71
031941-026x450/400		450	586				1.83
031941-026x500/400		500	636				1.95
031941-026x550/400		550	686				2.07
031941-026x600/400		600	736				2.19
031941-026x650/400		650	786				2.33
031941-026x700/400	700	836	2.45				
031941-036x100/400	36	100	256	74	40	46	1.04
031941-036x150/400		150	306				1.16
031941-036x200/400		200	356				1.28
031941-036x250/400		250	406				1.40
031941-036x300/400		300	456				1.54
031941-036x350/400		350	506				1.66
031941-036x400/400		400	556				1.80
031941-036x450/400		450	606				1.92
031941-036x500/400		500	656				2.04
031941-036x550/400		550	706				2.16
031941-036x600/400		600	756				2.28
031941-036x650/400		650	806				2.42
031941-036x700/400	700	856	2.54				
031941-046x100/400	46	100	276	84	50	56	2.37
031941-046x150/400		150	326				2.49
031941-046x200/400		200	376				2.61
031941-046x250/400		250	426				2.73
031941-046x300/400		300	476				2.87
031941-046x350/400		350	526				2.99
031941-046x400/400		400	576				3.13
031941-046x450/400		450	626				3.25
031941-046x500/400		500	676				3.37
031941-046x550/400		550	726				3.50
031941-046x600/400		600	776				3.63
031941-046x650/400		650	826				3.75
031941-046x700/400	700	876	3.87				

1) If the total of two adjacent cables ( $d_1 + d_2$ ) is smaller than the value  $\Sigma d$  of the table, spacers are required to separate the cables.  
See page 17 above.

# Accessories for Festoon Systems Program 0365, 0370 and 0375

## Spacers

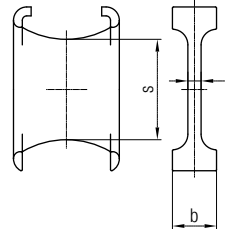
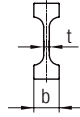
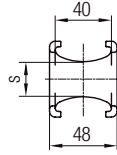

Broad version

Small version

Order No.	s [mm]	t [mm]	b [mm]	Appropriate Cable Clamp	Material	Version	Weight [kg]
031946-26	25	4	18	031941-026x...	Plastic	Small	0.010
031946-36	35	5	19	031941-036x...			0.015
031946-46	45	6	20	031941-046x...			0.025
031947-26	25	4	26	031941-026x...	Plastic	Broad	0.015
031947-36	35	5	27	031941-036x...			0.020
031947-46	45	6	28	031941-046x...			0.025

### Notes

- The above drawings are examples for illustration only
- Small version for cables with outer diameter smaller 14 mm and larger 22 mm
- Broad version for cables with outer diameter larger 14 mm and smaller 22 mm

## Flat Cable Clamps

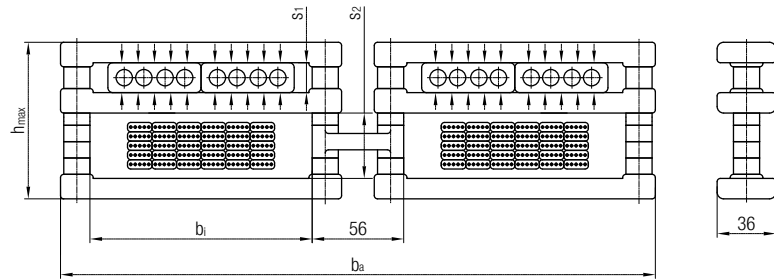

### Notes

- By changing the distance tubes from window  $s_2$  to window  $s_1$ , the flat cable clamp can be adjusted to fit the cable package
- The window with the dimension  $s_2$  must be adjusted to an appropriate dimension, so that the cables can move with sufficient clearance ( $> 15$  mm)

Order No.	$b_i$ [mm]	$b_a$ [mm]	$s_1 + s_2$ [mm]	$s_{1 \min}$ [mm]	$h_{\max}$ [mm]	Weight [kg]
031954-084x045/400	84	257	45	+2.5	5	80
031954-084x055/400			55			90
031954-084x065/400			65			100
031954-084x075/400			75			110
031954-084x085/400			85			120
031954-136x045/400	136	364	45	+2.5	5	80
031954-136x055/400			55			90
031954-136x065/400			65			100
031954-136x075/400			75			110
031954-103x085/400			85			120
031954-184x045/400	184	460	45	+2.5	5	80
031954-184x055/400			55			90
031954-184x065/400			65			100
031954-184x075/400			75			110
031954-184x085/400			85			120

# Accessories for Festoon Systems Program 0365, 0370 and 0375

## Flat Cable Clamps

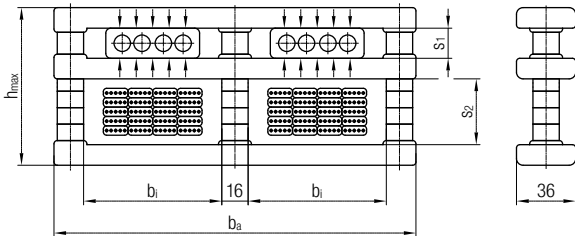

Order No.	b <sub>i</sub> [mm]	b <sub>a</sub> [mm]	S <sub>1</sub> + S <sub>2</sub> [mm]	S <sub>1 min</sub> [mm]	h <sub>max</sub> [mm]	Weight [kg]	
031955-084x045/400	84	220	45	+2.5	5	80	0.43
031955-084x055/400			55			90	0.44
031955-084x065/400			65			100	0.46
031955-084x075/400			75			110	0.48
031955-084x085/400			85			120	0.49
031955-103x045/400	103	258	45	+2.5	5	80	0.46
031955-103x055/400			55			90	0.47
031955-103x065/400			65			100	0.49
031955-103x075/400			75			110	0.51
031955-103x085/400			85			120	0.52

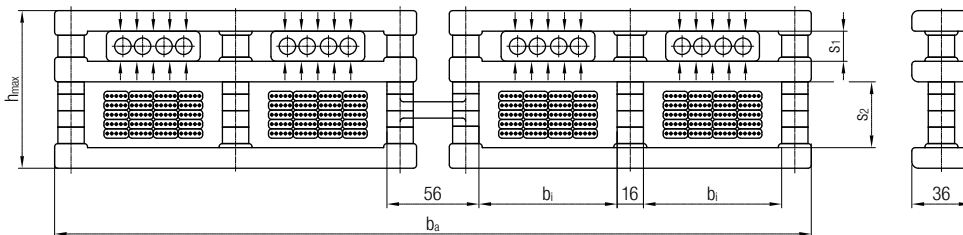

Order No.	b <sub>i</sub> [mm]	b <sub>a</sub> [mm]	S <sub>1</sub> + S <sub>2</sub> [mm]	S <sub>1 min</sub> [mm]	h <sub>max</sub> [mm]	Weight [kg]	
031956-084x045/400	84	424	45	+2.5	5	80	0.89
031956-084x055/400			55			90	0.92
031956-084x065/400			65			100	1.00
031956-084x075/400			75			110	1.03
031956-084x085/400			85			120	1.06
031956-103x045/400	103	500	45	+2.5	5	80	0.95
031956-103x055/400			55			90	0.98
031956-103x065/400			65			100	1.06
031956-103x075/400			75			110	1.09
031956-103x085/400			85			120	1.12

## Lifting Device

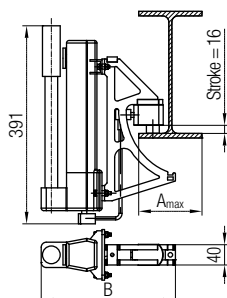

Order No.	Program	A <sub>max</sub> [mm]	B [mm]	Weight [kg]	I-Beam
039030-1	0365	150	265	5	IPE 240 G3192 250x125x6x9 W8x18
039030-2	0370 / 0375	220	311	6	IPB 200 G3192 200x200x8x12 W8x40

**Note**  
The lifting device can be used for lifting of the cable trolley during replacement of main rollers or side shields.

# Wear Parts for Cable Trolleys

## Program 0365, 0370 and 0375

### Replacement Rollers for Running Gear Types HMG and HMP

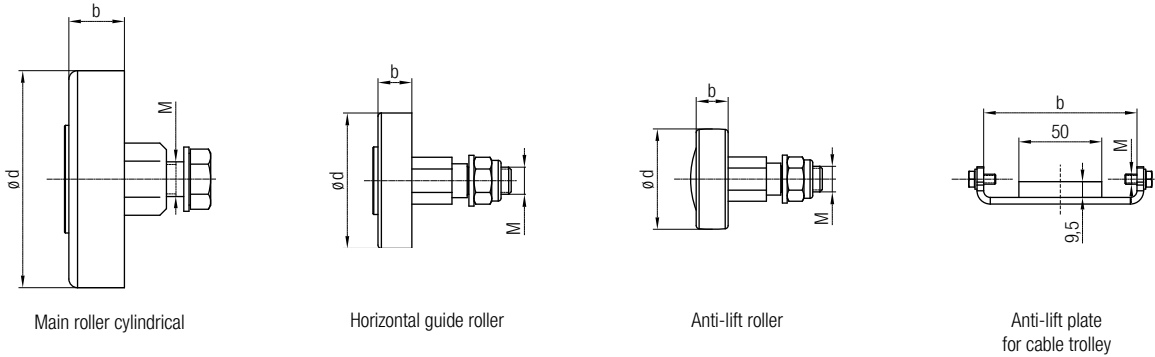

Order No.	Description	ø d [mm]	b [mm]	Thread M	Material Bandage	Weight [kg]
030120-112.1	Main roller cylindrical	112	27.5	M 20	Vulkollan	0.8
030121-112.1					Adiprene	
030120-125.1		125	32.0	M 20	Vulkollan	1.3
030121-125.1					Adiprene	
030120-160.1		160	50.0	M 24	Vulkollan	2.7
030121-160.1					Adiprene	
030122-063.1	Horizontal guide roller	63	16.5	M 12	Vulkollan	0.3
030123-063.1					Adiprene	
030122-080.1		80	20.0	M 16	Vulkollan	0.5
030123-080.1					Adiprene	
030122-112.1		112	27.5	M 20	Vulkollan	0.8
030123-112.1					Adiprene	
030124-063.1	Anti-lift roller	63	20.0	M 16	Stainless steel	0.6
030124-080.1		80	24.0			0.8
030125-0001	Anti-lift plate for towing trolley and end clamp and towing trolley for catenary trolley	-	120.0	M 8	Plastic	0.2
030125-0002	Anti-lift plate middle (towing trolley for towing trolley for catenary trolley)	-	194.0			
030125-0003	Anti-lift plate for towing trolley / -clamp	-	194.0	M 12		0.6

### Shock Cords

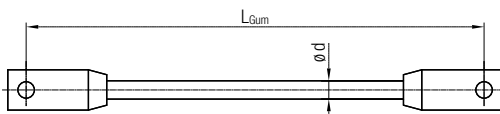

#### Technical details

- Shock cord: rubber with plastic plait
- Fasteners: stainless steel/hot-dipped galvanized steel

Order No.	ø d [mm]	Weight [kg/m]
031989-2	20	0.4
031996	28	0.6

#### Note

In case of order please state the lengths  $L_{Gum}$  of the respective shock cords.

# Wear Parts for Cable Trolleys

## Program 0365, 0370 and 0375

### Cellular Buffer 080x080

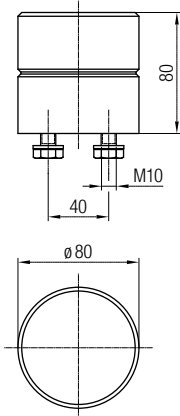

Order No. 031997-080x080

**Technical details**

- Material: polyurethan
- Weight: 0.3 kg
- For program 0365
- For cable trolley and towing trolley for catenary trolley

### Cellular Buffer 150x110x080

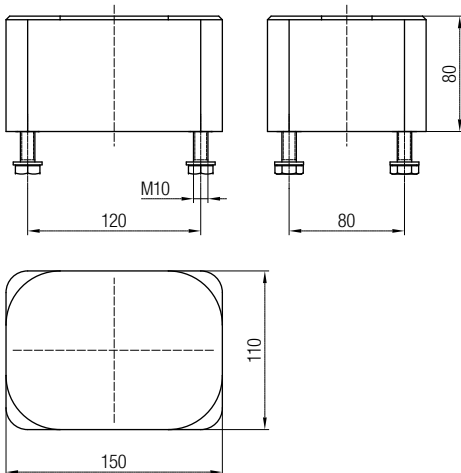

Order No. 031997-150x110

**Technical details**

- Material: Polyurethan
- Weight: 0.9 kg
- For program 0365 (only for towing trolley, end clamp and towing trolley for catenary trolley)
- For program 0370 and 0375

### Buffer Unit

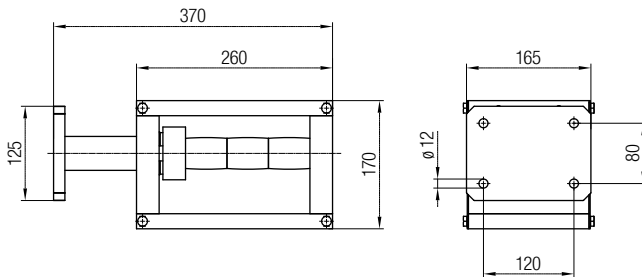

Order No. 039028

**Technical details**

- Material:
  - Housing aluminum seawater resistant
  - Rubber buffer
- Weight: 15 kg
- For program: 0365, 0370 und 0375
- Only for towing trolley, end clamp and towing trolley for catenary trolley
- Cellular buffer is not scope of delivery. For cellular buffers see 031997-150x100





# Spare Parts for Cable Trolleys Program 0365

## Side Shields Complete

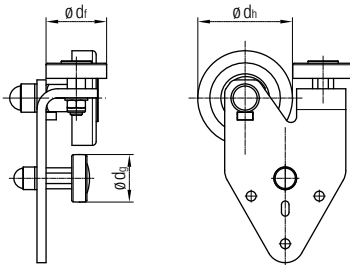

Running gear type HMG

### Complete side shields

#### consist of:

- Side shield
- Rollers mounted

### Program 0365 for running gear type HMG

Order No.	Weight [kg]	$\varnothing d_h$ [mm]	$\varnothing d_f$ [mm]	Material Bandage	$\varnothing d_a$ [mm]	Material Anti-Lift Roller	Flange	I-Beam
039020-112-0124	4.0	112	63	Vulkollan	63	Stainless steel	Parallel	IPE 240 G 3192 250x125x6x9 W8x18
039021-112-0124				Adiprene				
039020-125-0124	4.5	125	80	Vulkollan				
039021-125-0124				Adiprene				
039020-112-0022	4.0	112	63	Vulkollan	63	Stainless steel	Tapered flange	INP 220 G 3192 200x100x7x10x8° S8x18.4
039021-112-0022				Adiprene				
039020-125-0022	4.5	125	80	Vulkollan				
039021-125-0022				Adiprene				

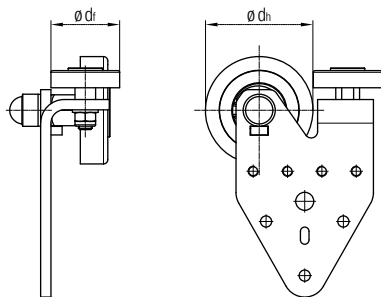

Running gear type HMP

### Complete side shields

#### consist of:

- Side shield
- Rollers mounted
- Running gear type HMP without anti-lift plate

### Program 0365 for running gear type HMP<sup>1)</sup>

Order No.	Weight [kg]	$\varnothing d_h$ [mm]	$\varnothing d_f$ [mm]	Material Bandage	Flange	I-Beam
039022-112-0124	3.5	112	63	Vulkollan	Parallel	IPE 240 G 3192 250x125x6x9 W8x18
039023-112-0124				Adiprene		
039022-125-0124	4.0	125	80	Vulkollan		
039023-125-0124				Adiprene		
039022-112-0022	3.5	112	63	Vulkollan	Tapered flange	INP 220 G 3192 200x100x7x10x8° S8x18.4
039023-112-0022				Adiprene		
039022-125-0022	4.0	125	80	Vulkollan		
039023-125-0022				Adiprene		

<sup>1)</sup> without anti-lift plate; for anti-lift plate see page 20 in this catalog

# Spare Parts for Cable Trolleys

## Program 0365

### Running Gear Complete

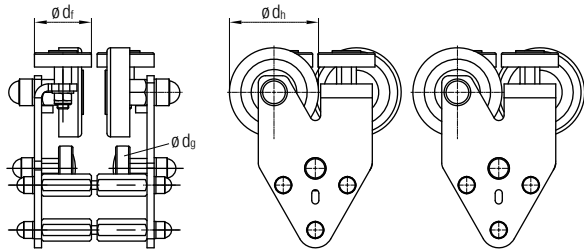

Running gear type HMG

#### Complete running gears

##### consist of:

- 4 side shields complete
- Distance bolts
- Fasteners

#### Program 0365 for running gear type HMG

Order No.	Weight [kg]	$\varnothing d_h$ [mm]	$\varnothing d_f$ [mm]	Material Bandage	$\varnothing d_g$ [mm]	Material Anti-Lift Roller	Flange	I-Beam
037652-0124	20	112	63	Vulkollan	63	Stainless steel	Parallel	IPE 240 G 3192 250x125x6x9 W 8x18
037662-0124				Adiprene				
038652-0124	22	125	80	Vulkollan				
038662-0124				Adiprene				
037652-0022	20	112	63	Vulkollan	63	Stainless steel	Tapered flange	INP 220 G 3192 200x100x7x10x8° S 8x18.4
037662-0022				Adiprene				
038652-0022	22	125	80	Vulkollan				
038662-0022				Adiprene				

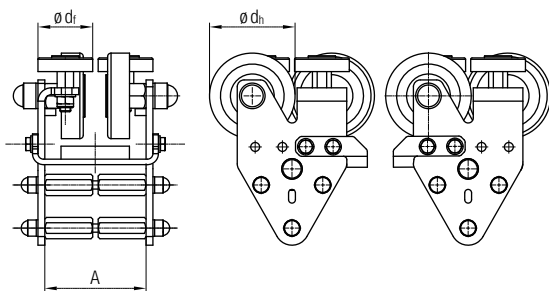

Running gear type HMP

#### Complete running gears

##### consist of:

- 4 side shields complete
- Distance bolts
- Fasteners
- Running gear type HMP, anti-lift roller included

#### Program 0365 for running gear type HMP

Order No.	Weight [kg]	$\varnothing d_h$ [mm]	$\varnothing d_f$ [mm]	Material Bandage	A [mm]	Material Anti-Lift Plate	Flange	I-Beam
037655-0124	20	112	63	Vulkollan	168	Plastic	Parallel	IPE 240 G 3192 250x125x6x9 W 8x18
037665-0124				Adiprene				
038655-0124	22	125	80	Vulkollan				
038665-0124				Adiprene				
037655-0022	20	112	63	Vulkollan	168	Plastic	Tapered flange	INP 220 G 3192 200x100x7x10x8° S 8x18.4
037665-0022				Adiprene				
038655-0022	22	125	80	Vulkollan				
038665-0022				Adiprene				

# Spare Parts for Cable Trolleys

## Program 0365

### Running Gear complete

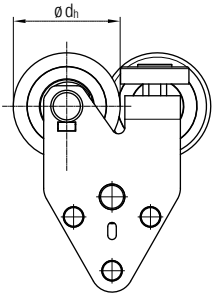

Running gear type HMG

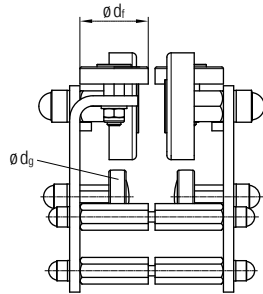

Complete running gears for towing trolley and towing trolley for catenary trolley consist of:

- 2 side shields complete
- 2 fasteners incl. roller
- 2 rollers complete

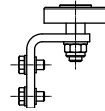

Fastener incl. roller

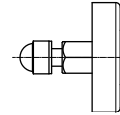

Roller complete

### Program 0365 running gear type HMG for towing trolley and towing trolley for catenary trolley

Order No.	Weight [kg]	$\varnothing d_h$ [mm]	$\varnothing d_r$ [mm]	Material Bandage	$\varnothing d_g$ [mm]	Material Anti-Lift Roller	Flange	I-Beam
037652-2-0124	3.5	112	63	Vulkollan	63	Stainless steel	Parallel	IPE240 G3192 250x125x6x9
037662-2-0124				Adiprene				
038652-2-0124	4.0	125	80	Vulkollan	63	Stainless steel	Parallel	250x125x6x9 W8x18
038662-2-0124				Adiprene				
037652-2-0022	3.5	112	63	Vulkollan	63	Stainless steel	Tapered flange	INP220 G3192 200x100x7x10x8°
037662-2-0022				Adiprene				
038652-2-0022	4.0	125	80	Vulkollan	63	Stainless steel	Tapered flange	200x100x7x10x8° S8x18.4
038662-2-0022				Adiprene				

# Spare Parts for Cable Trolleys Program 0370 and 0375

## Side Shields complete

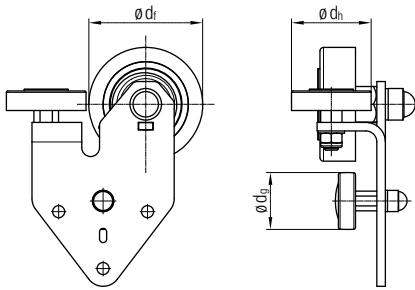

Running gear type HMG (Side shield left)

### Complete side shields

#### consist of:

- Side shield
- Rollers mounted

### Program 0370 and 0375 for running gear type HMG side shield left

Order No.	Weight [kg]	$\varnothing d_h$ [mm]	$\varnothing d_f$ [mm]	Material Bandage	$\varnothing d_g$ [mm]	Material Anti-Lift Roller	Flange	I-Beam
039024-125-L-0220	7.0	125	80	Vulkollan	63	Stainless steel	Parallel	IPB 200 G 3192 200x200x8x12 W 8x40
039025-125-L-0220				Adiprene				
039024-160-L-0220	7.8	160	112	Vulkollan	80			
039025-160-L-0220				Adiprene				

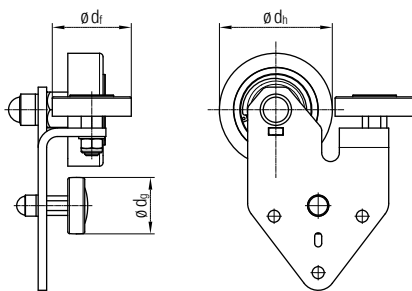

Running gear type HMG (Side shield right)

### Complete side shields

#### consist of:

- Side shield
- Rollers mounted

### Program 0370 and 0375 for running gear type HMG side shield right

Order No.	Weight [kg]	$\varnothing d_h$ [mm]	$\varnothing d_f$ [mm]	Material Bandage	$\varnothing d_g$ [mm]	Material Anti-Lift Roller	Flange	I-Beam
039024-125-R-0220	7.0	125	80	Vulkollan	63	Stainless steel	Parallel	IPB 200 G 3192 200x200x8x12 W 8x40
039025-125-R-0220				Adiprene				
039024-160-R-0220	7.8	160	112	Vulkollan	80			
039025-160-R-0220				Adiprene				

# Spare Parts for Cable Trolleys

## Program 0370 and 0375

### Running Gear Complete

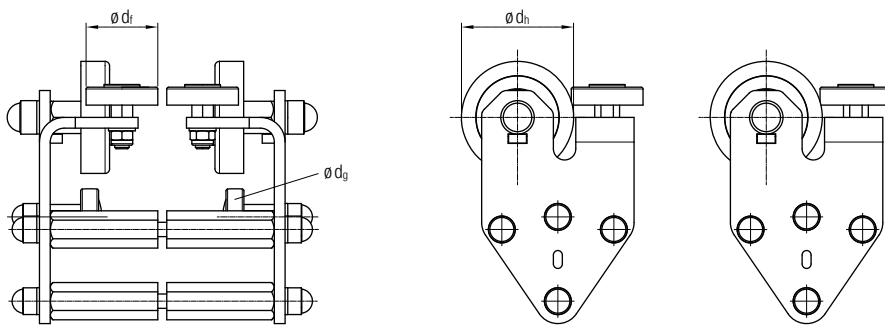

Running gear type HMG

#### Complete running gears

- consist of:
- 4 side shields complete
  - Distance bolts
  - Fasteners

### Program 0370 and 0375 for running gear type HMG

Order No.	Weight [kg]	$\varnothing d_h$ [mm]	$\varnothing d_f$ [mm]	Material Bandage	$\varnothing d_g$ [mm]	Material Anti-Lift Roller	Flange	I-Beam
038952-0220	40	125	80	Vulkollan	63	Stainless steel	Parallel	IPB 200 G 3192 200x200x8x12 W 8x40
038962-0220				Adiprene				
039952-0220	44	160	112	Vulkollan				
039962-0220				Adiprene				

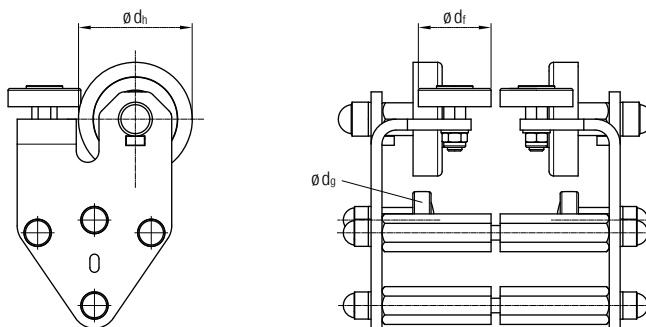

Running gear type HMG

#### Complete running gears for towing trolley and towing trolley for catenary trolley

- consist of:
- 2 side shields
  - 2 fasteners incl. roller
  - 2 rollers complete

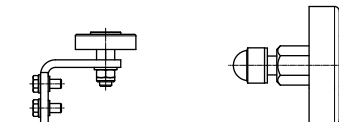

Fastener incl. roller

Roller complete

### Program 0370 and 0375 running gear type HMG for towing trolley and towing trolley for catenary trolley

Order No.	Weight [kg]	$\varnothing d_h$ [mm]	$\varnothing d_f$ [mm]	Material Bandage	$\varnothing d_g$ [mm]	Material Anti-Lift Roller	Flange	I-Beam
038952-2-0220	40	125	80	Vulkollan	63	Stainless steel	Parallel	IPB 200 G 3192 200x200x8x12 W 8x40
038962-2-0220				Adiprene				
039952-2-0220	44	160	112	Vulkollan				
039962-2-0220				Adiprene				

# Technical Appendix

## Specification of Preference Range I-Beams

### Dimensions of the Standard I-Beams for Program 0365 Parallel Flange

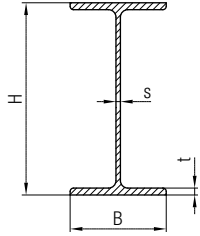

Country	Description	H [mm]	B [mm]	s [mm]	t [mm]	I-Beam Code
Europe	IPE 240	240 ± 4	120 <sup>+4</sup> <sub>-2</sub>	6.9 ± 0.7	9.8 ± 1	0124
Japan	G3192 250x125x6x9	250 ± 2	125 ± 2.5	6.0 ± 0.7	9.0 ± 1	0124
USA	W8x18	206 <sup>+4</sup> <sub>-3</sub>	133 <sup>+6</sup> <sub>-5</sub>	5.8 ± 0.7	8.4 ± 0.7	0124

### Dimensions of the Standard I-Beams for Program 0365 Tapered Flange

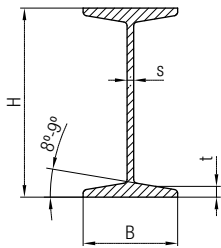

Country	Description	H [mm]	B [mm]	s [mm]	t [mm]	I-Beam Code
Europe	INP 220	220 ± 3	98 ± 2	8.1 ± 0.7	12.2 <sup>+2</sup> <sub>-1</sub>	0022
Japan	G3192 200x100x7x10x8°	200 ± 2	102 ± 2	7.0 ± 1	10.0 ± 1	0022
China	GB 706-65/20a	200 ± 2	102 ± 2	7.0 ± 1	11.4 ± 1	0022
USA	S8x18.4	203 <sup>+3</sup> <sub>-2</sub>	102 ± 3	6.8 ± 1	10.8 ± 0.7	0022

### Dimensions of the Standard I-Beams for Program 0370 and 0375 Parallel Flange

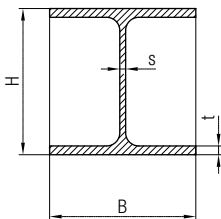

Country	Description	H [mm]	B [mm]	s [mm]	t [mm]	I-Beam Code
Europe	IPB 200	200 <sup>+4</sup> <sub>-2</sub>	200 <sup>+4</sup> <sub>-2</sub>	9.0 ± 1	15.0 <sup>+4</sup> <sub>-2</sub>	0220
Japan	G3192 200x200x8x12	200 ± 2	200 ± 2	8.0 ± 0.7	12.0 ± 1	0220
USA	W8x40	209 <sup>+4</sup> <sub>-3</sub>	205 <sup>+6</sup> <sub>-5</sub>	9.1 ± 1	14.0 <sup>+2</sup> <sub>-1</sub>	0220

# Your Applications - our Solutions!

Festoon Systems by Conductix-Wampfler represent only one of the many solutions made possible by the broad spectrum of Conductix-Wampfler components for the transport of energy, data and fluid media. The solutions we deliver for your applications are based on your specific requirements. In many cases, a combination of several different Conductix-Wampfler systems can prove advantageous. You can count on all of Conductix-Wampfler's Business Units for hands-on engineering support - coupled with the perfect solution to meet your energy management and control needs.

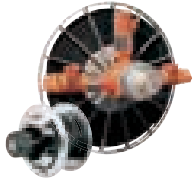

### Cable reels

Motorized reels and spring reels by Conductix-Wampfler hold their own wherever energy, data and media have to cover the most diverse distances within a short amount of time - in all directions, fast and safe.



### Festoon systems

It's hard to imagine Conductix-Wampfler cable trolleys not being used in virtually every industrial application. They're reliable and robust and available in an enormous variety of dimensions and designs.



### Conductor rails

Whether they're enclosed conductor rails or expandable single-pole systems, the proven conductor rails by Conductix-Wampfler reliably move people and material.



### Non-insulated conductor rails

Extremely robust, non-insulated conductor rails with copper heads or stainless steel surfaces provide the ideal basis for rough applications, for example in steel mills or shipyards.



### Energy guiding chains

The "Jack of all trades" when it comes to transferring energy, data, air and fluid hoses. With their wide range, these energy guiding chains are the ideal solution for many industrial applications.



### Slip ring assemblies

Whenever things are really "moving in circles", the proven slip ring assemblies by Conductix-Wampfler ensure the flawless transfer of energy and data. Here, everything revolves around flexibility and reliability!



### Inductive Power Transfer IPT®

The no-contact system for transferring energy and data. For all tasks that depend on high speeds and absolute resistance to wear.



### Reels, retractors and balancers

Whether for hoses or cables, as classical reels or high-precision positioning aids for tools, our range of reels and spring balancers take the load off your shoulders.



### Jib boom

Complete with tool transporters, reels, or an entire media supply system - here, safety and flexibility are key to the completion of difficult tasks.



### Conveyor systems

Whether manual, semiautomatic or with Power & Free – flexibility is achieved with full customization concerning layout and location.

# www.conductix.com

---

**Conductix-Wampfler GmbH**

Rheinstrasse 27+33  
79576 Weil am Rhein  
Germany

Hotline

Phone +49 (0) 7621 662-222

Phone +49 (0) 7621 662-0

Fax +49 (0) 7621 662-144

info.de@conductix.com

www.conductix.com



Ⓞ DELACHAUX GROUP