

# Conductor Rail System

## EcoClickLine Program 0832

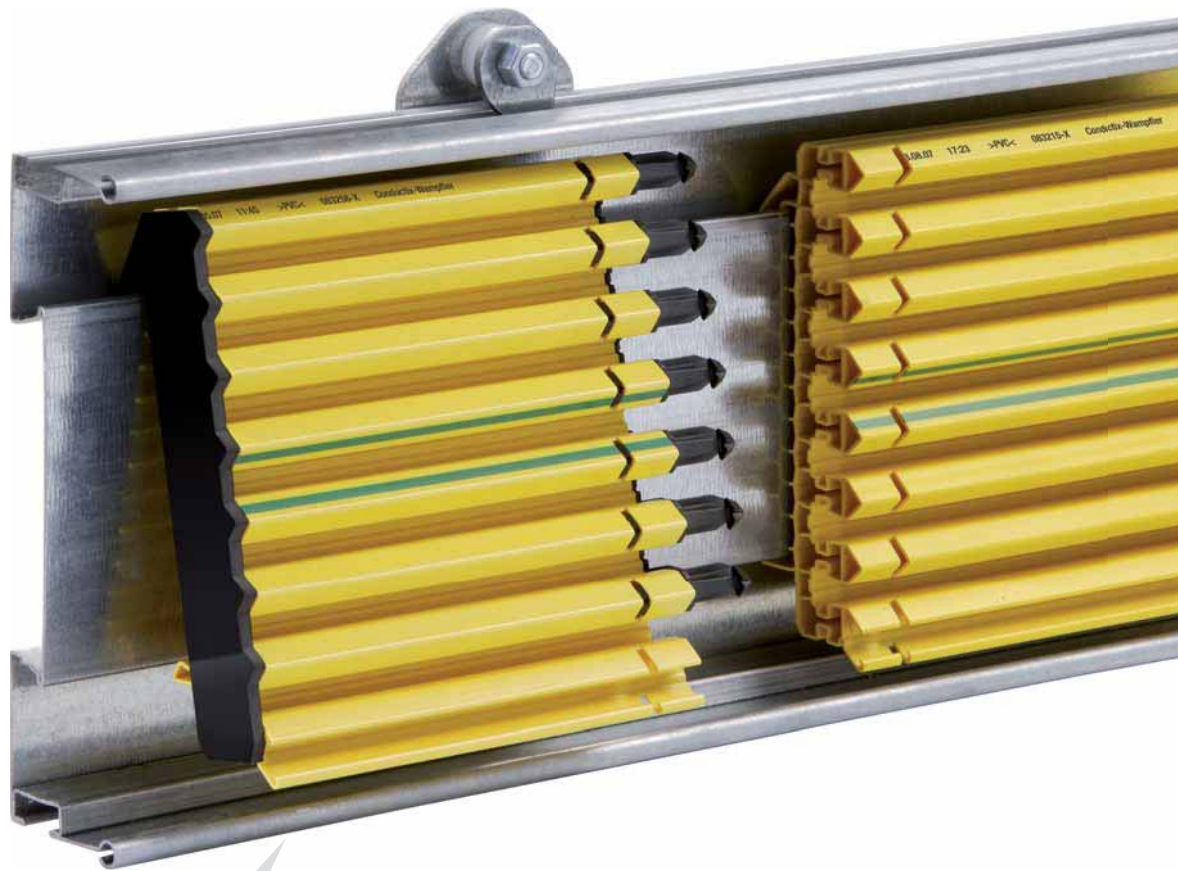

**CONDUCTIX**  
wampfler

© DELACHAUX GROUP



# Contents

---

## System and Module Concept

EcoClickLine - a system introduces itself! . . . . .	2
The System . . . . .	4
The Module Concept . . . . .	5
EcoClickLine I How long should it be? . . . . .	6
Technical Data . . . . .	7

---

## Module Selection

Overview Regarding the Number of Modules per Shelf Aisle . . . . .	8
--	---

---

## Standard Modules

Basic Module 0832 . . . . .	9
Expansion Module 0832 . . . . .	9
Conductor Strip Module . . . . .	10

---

## Additional Modules

System Hanger . . . . .	11
Consoles . . . . .	11
Adapter . . . . .	11
Positioning Module . . . . .	12
Overview of Bar Code Assembly . . . . .	12
Funnel / Pick Up Guide . . . . .	13
Power Feed . . . . .	13
Conductor Strip Connector . . . . .	14
Expansion Module . . . . .	15

---

## Current Collector

Current Collector 2 x 80A . . . . .	16
Change Support for Current Collector 1 x 80A and 2 x 80A . . . . .	16
Current Collector 1 x 80A . . . . .	17

---

## Tools and Assembly Aids

General Information . . . . .	18
Tool Set STANDARD and PROFI . . . . .	18

---

## Wear and Spare Parts

Repair Module . . . . .	19
Small Parts Service Package . . . . .	19
Current Collector - Spare Parts . . . . .	19
End Cap . . . . .	20
Insulating Connector . . . . .	20
Connector Set . . . . .	20
Insulation and Support Profiles . . . . .	20
Bar Code Band - Spare Parts . . . . .	20

---

## System

System Dimensions / Installation Instructions . . . . .	21
---	----

---

## Other Information

Frequently Asked Questions . . . . .	22
Questionnaire . . . . .	23
Tailored Service . . . . .	24

---

### Note

Images and illustrations used are examples and can vary from the product depending on the version. Subject to change without notification.

---

# EcoClickLine - a system introduces itself!

## Tailored ready made

**EcoClickLine** has been specially developed for the requirements of AS/RS cranes in high rack storage areas and similar linear applications such as transfer cars.

As a sturdy and reliable system **EcoClickLine** fulfills the requirements of current and future storage and retrieval systems: In addition to linking product advantages of known systems, consequent implementation of mostly tool-free assembling techniques as well as the module concept of the system are also unique.

## Savings during assembly and logistics

These product characteristics can save considerable costs in the area of assembly and transport and therefore allow the entire costs for system constructors and final customers to be significantly reduced. The system greatly reduces assembly time. This is made possible by several clever detail solutions such as clip connectors and snap locks. The necessary force and form-fit connections are easily accessible. The use of small parts has been reduced to a minimum.

## Advantages through module concept

Another advantage is found in the module concept of the conductor rail systems: In contrast to the usual assembly of individual parts, the system comes in modules. A module contains all of the parts needed for one section. As a result, not only is it possible to assemble your system quickly and safely, the continuous logistical procedure remains free from errors to its destination. With the exception of both modules for the conductor strips and positioning modules that are manufactured shelf aisle-specific and according to order, all modules are universally applicable standard modules.

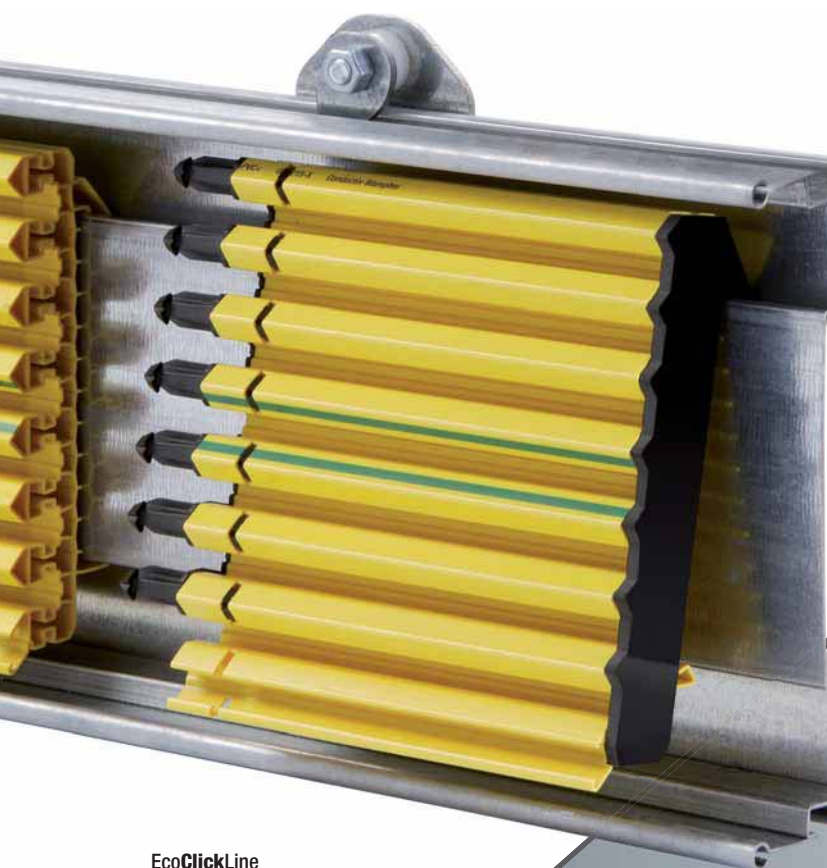

**EcoClickLine**  
The Economical Standard for AS/RS

## The System

- Clip-in section connectors for quick connection of the insulating sections
- Tool-free, continuous fixation of the insulating section
- System hanger with snap lock

**Reduction of  
assembly times by  
up to 50%!**

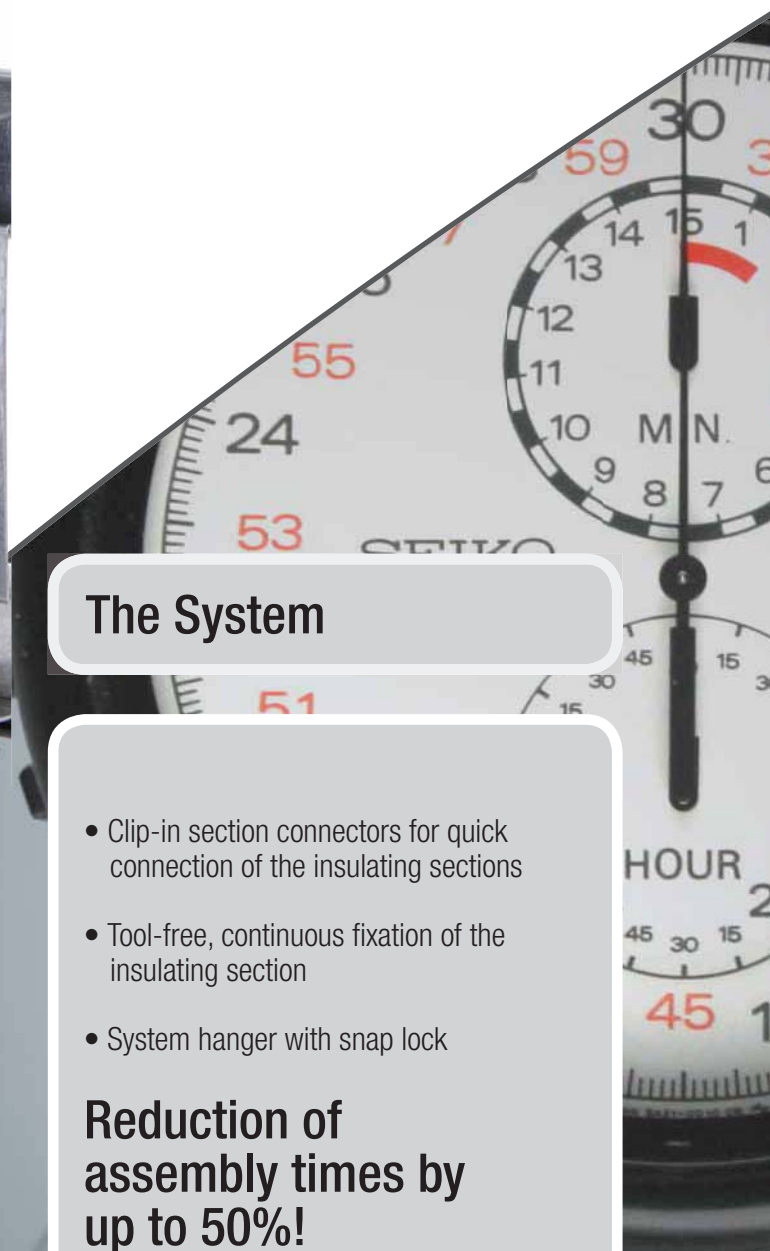



With EcoClickLine you reduce the costs for assembly and logistics and therefore the total costs up to 50%!

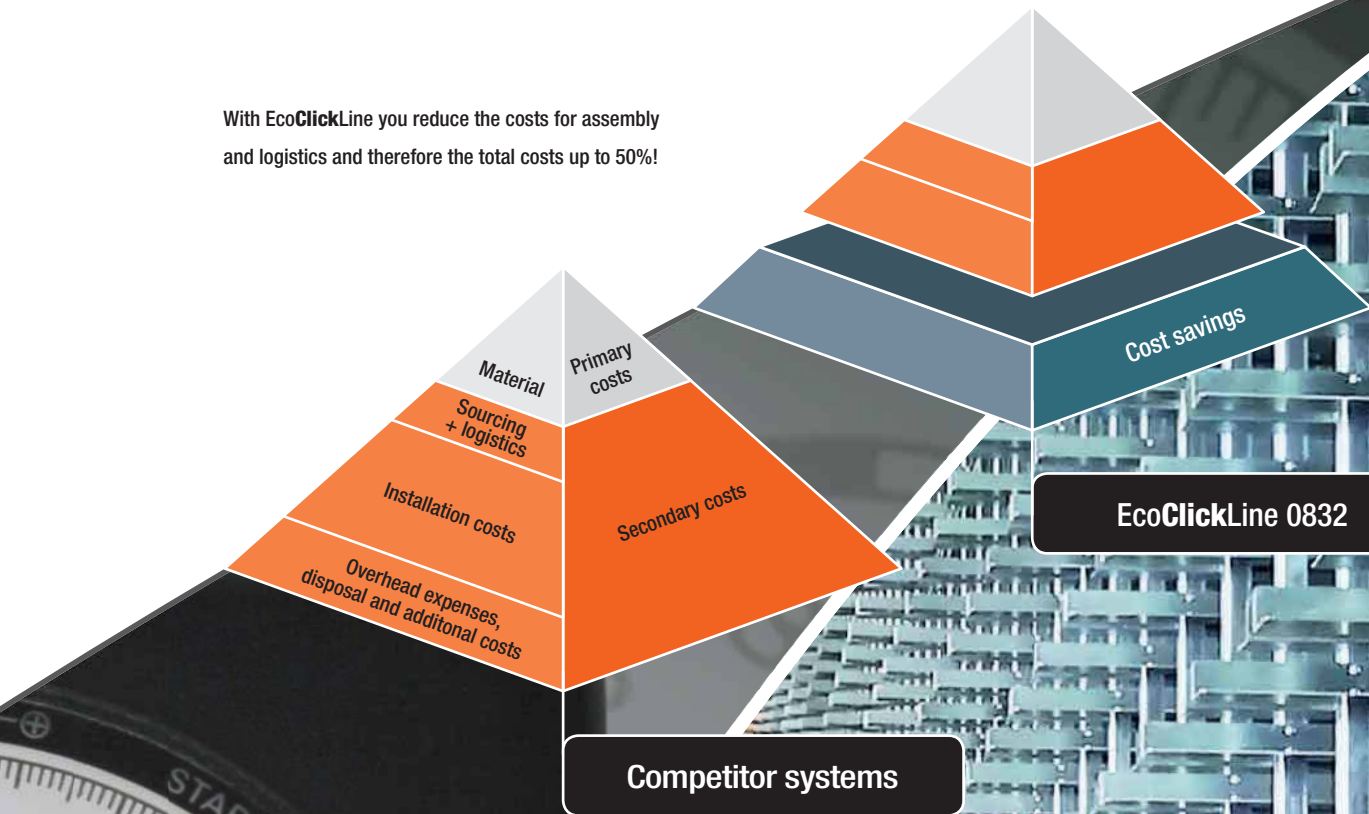

## The Module Concept

- Easy to assemble
- Assembly-oriented logistics
- Requirement-oriented selection of additional modules such as special components, tools, transport aids, etc

**Reduction of logistic costs by up to 50%!**

# The System



**Tool-free assembly** through clip-in profile connectors



**Snap lock** through system hanger



**75% reduction of screws** due to support profile connections with screw optimization

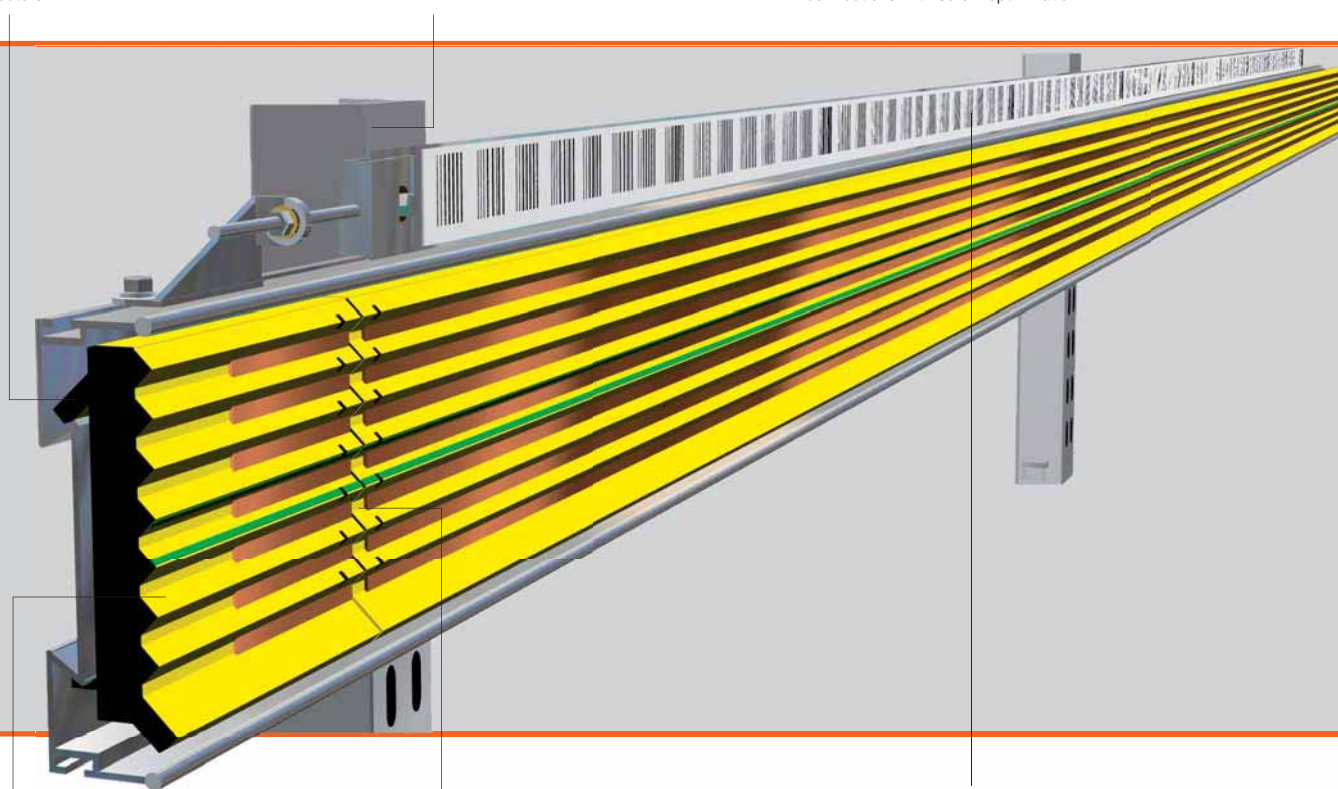

**Flexible conductor strip assembly** through easy manual feed

**Quick connection** through clip-in profile connectors

**Easy integration of system expansions** through integrated receptacle for bar code positioning or data transfer systems



**Flexibly expandable** due to continuous T notches to support switching flags, control magnets or RFID transponders



# The Module Concept

**EcoClickLine** is based on the combination of universally applicable standard modules and a tailored-to-order, built ready-for-assembly conductor strip module. A transparent and easy to handle number of packages with compact measurements and light individual weight is directly transported to the installation site in the shelf aisle. All of the materials needed at the

installation site are therefore available in sufficient quantity and at the right place. Only a few initial data are needed to order or to select the modules.

**The EcoClickLine initial data for product configuration:**

- Project and shelf aisle description
- Length of the aisle
- Pole assignment / conductor cross section
- Hang-up distance and shelf type
- Number and type of current collectors
- Environmental temperature range

## Standard Modules



**Basic module L 1-4 m**

- Support and insulation profiles
- Power feed and end caps
- Connector and spare parts



**Expansion module 4 m, 8 m or 24 m**

- 1, 2 or 6 support profiles each 4 m
- 1, 2 or 6 insulation profiles each 4 m
- Connector and spare parts



**Conductor strip package**

- Ready for assembly in desired feed length
- Including connection cables for the power feed



**Current collector**

- Ready for assembly
- Design up to 7 poles
- Left and right design

## Additional Modules



**Additional power feed**



**Consoles**



**Positioning / bar code band**



**Tool set**

# EcoClickLine | How long should it be?

With **EcoClickLine** orders with long item lists and the risk of forgetting something are a thing of the past. Broken down into a few modules identical for each order, which can be supplemented by one or two order-specific items, orders and deliveries are now straightforward and can be processed and checked within a matter of minutes.

The module system by **EcoClickLine** is structured so that all materials for a lane section or a function component are packaged together and can be transported into the shelf aisles at the installation site in easy to handle units. Customer picking or searching for parts in a collection of boxes or cartons at the construction site are now things of the past. All standard modules can be used according to the system.

By combining a basic module that includes all of the single parts of the conductor rail system such as end caps, power feed, anchor points, etc. with one or more expansion modules in package sizes of 4, 8 and 24 m, systems can be extended to any given length.

System-related components are limited here to the lengths and numbers of conductor strips as well as to the connection cables of the power feed. These components are manufactured on short notice according to order and packaged ready for assembly and ready for dispatch according to shelf aisle.

An order and delivery therefore always is comprised of the same units (basic and expansion modules) as well as an assembly-ready packaging unit with the conductor strips.

**Example combination of a shelf aisle length of 39 m:**

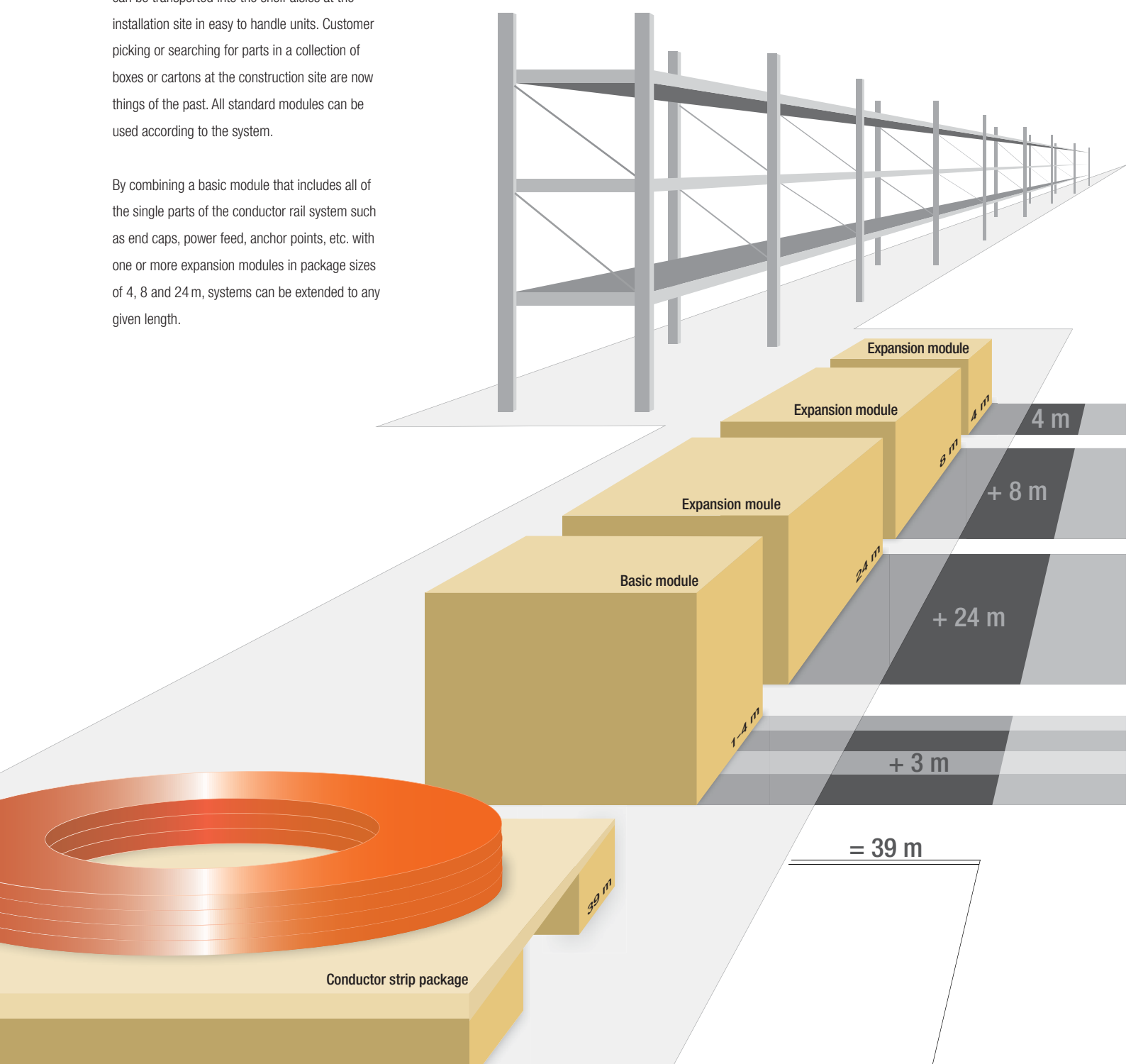



# Technical Data

System:	4 to 7 pole conductor rail for shelf aisle supply in high rack storage systems and for transfer cars
Installation position:	vertical setup (current collector contact on the side)
Hang-up distance:	nominal rated distance 3.2 m
max. length:	infinitely / expandable through conductor strip connectors
Speedrated:	$V_{max}$ 600 m/min (straight strips)
Voltage (UL):	690V (600V)
Environmental temperature:	-30°C to + 55°C (max. temperature difference $\Delta T = 50$ K)
Protection type:	IP 23
Chemical stability:	Benzine, mineral oil, fatscaustic
PVC material:	soda 25%, hydrochloric acid concentrated, sulfuric acid 50% Data based on 45°C environmental temperature and temporary effect while taking damage not considered to be critical to function into consideration (e.g. traces of oxidation, discoloration)
Additional functions:	Path positioning (optional with bar code or slit code band), data transfer (optional)
Funnel function:	Tangential entry at any position possible. Entry funnel at the end of the conductor rail optional
Position PE:	4th pole from above

## External measurements, weights, system grid

Height:	196 mm (220 mm including system hanger)
Depth:	48 mm (50mm including system hanger)
System length:	4000 mm
System grid:	1 m (intermediate measurement by easy cut possible)
Weight:	5.4 to 6.5 kg/m (depending on conductor equipment)

## Main components

<b>Support profile</b>	Deflection resistant, formed sheet steel sections (galvanized)
weight:	1.5 kg/m
<b>Insulate profile</b>	stabilized hard PVC; color YELLOW (RAL 1018)
Dielectric strength:	22.4 kV/mm according to DIN 53481
Creep resistance:	400 < CTI according to IEC 112 / VDE 0303
Flammability:	corresponding the requirements for insulating materials according to UL 94 V-0; severely flammable and self-extinguishing (IEC) DIN EN 60895-11-10B
Weight:	3.3 kg/m
<b>Conductor strips:</b>	E-copper strips with V profile

Cross Section	[mm <sup>2</sup> ]	10	16	25	35	50
Resistance	[Ohm/1000 m]	1.73	1.08	0.69	0.49	0.35
Impedance at 50 Hz	[Ohm/1000 m]	1.74	1.11	0.74	0.53	0.39
Rated Current According to DIN	[A]	35	63	100	140 <sup>1)</sup>	200 <sup>1)</sup>
Weight	[kg/100 m]	9.8	13.9	22.4	31.6	42.8
Max. Coil Length	[m]	300	300	175	125	80

1) Mode of operation S5/80% Duty cycle

Configuration: Cross section at will according to application and feed concept

## Relevant standards

DIN EN 60664-1; VDE 0110-1:2008-01	Insulation coordination for electrical equipment in low voltage systems - Part 1: Principles, requirements and tests (IEC 60664-1:2007); German version EN 60664-1:2007
DIN EN 60204-1; VDE 0113-1:2007-06	Machine Safety - Electrical Equipment of Machines - Part 1: General requirements (IEC 60204-1:2005, modified); German version EN 60204-1:2006
DIN EN 60529; VDE 0470-1:2000-09	Systems of protection through housing (IP-Code) (IEC 60529:1989 + A1:1999); German version EN 60529:1991 A1:2000
DIN EN 60243-2; VDE 0303-22:2001-10	Electrical puncture strength of insulating materials - Test procedures- Part 2: Additional requirements for testing with direct current (IEC 60243-2:2001); German version EN 60243-2:2001
DIN IEC 60093; VDE 0303-30:1993-12	Testing procedures for electrical insulating materials; specific puncture strength and specific surface strength of fest, electrical insulating materials (IEC 60093:1980); German version HD 429 S1:1983
DIN IEC 60167; VDE 0303-31:1993-12	Test procedures for electrical insulating materials, insulation resistance of firm insulating materials (IEC 60167:1964); German version HD 568 S1:1990
DIN EN 60112; VDE 0303-11:2003-11	Procedure for the determination of the test number and of the index number of the spark checking of firm insulating materials (IEC 60112:2003); German version EN 60112:2003

# Module Selection

## Overview Regarding the Number of Modules per Shelf Aisle

The combination of the basic module with additional expansion modules allows any aisle length in the grid of 1 m. Intermediate sizes are easily and quickly created by shortening the last section at the construction site.

Number of modules needed for aisles of up to 120 m (randomly extendable).

Aisle Length [m]	Basic Module 1 - 4 [m]	24 [m]	Expansion Module 8 [m]	4 [m]
Order No.	083258-710x12	083215-024x7x12	083215-008x7x12	083215-004x7x12
10 - 12	1	0	1	0
13 - 16	1	0	1	1
17 - 20	1	0	2	0
21 - 24	1	0	2	1
25 - 28	1	1	0	0
29 - 32	1	1	0	1
33 - 36	1	1	1	0
37 - 40	1	1	1	1
38 - 44	1	1	2	0
45 - 48	1	1	2	1
49 - 52	1	2	0	0
53 - 56	1	2	0	1
57 - 60	1	2	1	0
61 - 64	1	2	1	1
65 - 68	1	2	2	0
69 - 72	1	2	2	1
73 - 76	1	3	0	0
77 - 80	1	3	0	1
81 - 84	1	3	1	0
85 - 88	1	3	1	1
89 - 92	1	3	2	0
93 - 96	1	3	2	1
97 - 100	1	4	0	0
101 - 104	1	4	0	1
105 - 108	1	4	1	0
109 - 112	1	4	1	1
113 - 116	1	4	2	0
117 - 120	1	4	2	1

**1 x Conductor Strip Module** page 10

**n x Expansion Module** (rated length of expansion module = 1000 mm) page 15

### Additional Assemblies and Components

- Current collectors page 16
- System hanger page 11
- Consoles page 11
- Conductor strip connections in case the max. roll length is exceeded page 14

### Additional Modules

- Positioning module (bar code band system for Leuze BPS laser) page 12
- Holder for coding strip (P+F) page 12
- Entry funnel and additional power feeds page 13
- Additional system expansions are possible (data transfer, crossing sections etc .)



3 standard modules for each aisle length

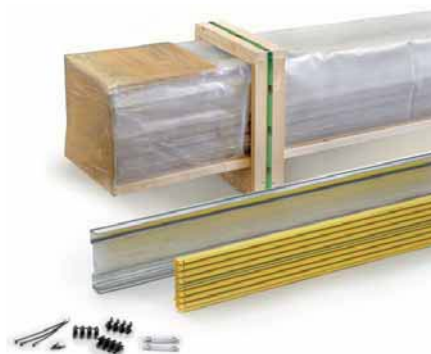

Expansion module 24 m with all assembly parts



Conductor strip package ready for assembly

# Standard Modules

## Basic Module 0832



### Description

The basic module includes all of the single components necessary for aisle supply such as the power feed with integrated anchor point, end caps as well as material to setup a aisle of 1 to 4 m.

With the division into 4 partial sections of 1 m each, a meter grid can be assembled without extra cutting. In addition, the short part lengths can be used in case of possible collisions at connection points.

### Contents

- 1 x power feed with anchor point pre-mounted including support frames for simple integration into the supporting section L = 1m
- 3 x supporting section L = 1 m; including insulating section L = 1 m
- 1 x set of end caps (1 x RI / 1 x LE) each 150 mm
- 1 x set of assembly material
- 1 x assembly instructions
- 1 x small parts service package

Order No.	System Length [m]	Weight [kg]
083258-710x12	1 to 4	20.5

The module can be used for all versions irrespective of the conductor strip assembly. The connection cables needed for the power feed are part of the scope of delivery of the conductor strip module and are included depending on the conductor configuration chosen and desired length.

## Expansion Module 0832



### Description

The expansion module includes all of the track components including the assembly material for the connection of the support and insulation profiles. The insulation profile have already been implemented at the plant into the support profile and can therefore be taken out of the packaging and directly placed and fixated into the mounted system hanger.

Order No.	083215-024x7x12	083215-008x7x12	083215-004x7x12
<b>Contents</b>			
Steel support profile	6 x 4 m	2 x 4 m	1 x 4 m
Insulation profile	6 x 4 m	2 x 4 m	1 x 4 m
Connector parts	included	included	included
<b>Packaging</b>			
Fork lift accessible	yes	no	no
Shape	coil	coil	carton / coil
Dimensions (L/B/H)	[mm] 4000 x 250 x 400	4050 x 215 x 90	4050 x 215 x 60
Gross weight	[kg] 110	38	19

# Standard Modules

## Conductor Strip Module

**EcoClickLine** allows for flexible assembly of the conductor rail with 5 different shaped conductor strips made of E-copper.

Cross sections of 10, 16, 25, 35 and 50 mm<sup>2</sup> are available to choose from. The new shapes for continuous conductor strips are based on technology from other conductor rail programs of the Conductix-Wampfler Group. The V geometry guides the brush safely and with less wear into the conductor strip. Elaborate guide constructions prone to errors such as current collector carriers are not necessary. The tried and proven electrical supply via the single current collector allows for good accessibility and simple handling for service.

### Preferred configuration

#### 7 pole

Configuration	7/10	7/16	7/25	7/35	7/50
1. pole	10	16	25	35	50
2. pole	10	16	25	35	50
3. pole	10	16	25	35	50
4. pole PE	10	16	16	16	25
5. pole	10	10	10	10	10
6. pole	10	10	10	10	10
7. pole	10	10	10	10	10

#### 6 pole

Configuration	6/10	6/16	6/25	6/35	6/50
1. pole	10	16	25	35	50
2. pole	10	16	25	35	50
3. pole	10	16	25	35	50
4. pole PE	10	16	16	16	25
5. pole	10	10	10	10	10
6. pole	10	10	10	10	10

#### 5 pole

Configuration	5/10	5/16N	5/25N	5/35N	5/50N
1. pole	10	16	25	35	50
2. pole	10	16	25	35	50
3. pole	10	16	25	35	50
4. pole PE	10	16	16	16	25
5. pole	10	16	25	35	50

#### 4 pole

Configuration	4/10	4/16	4/25	4/35	4/50
1. pole	10	16	25	35	50
2. pole	10	16	25	35	50
3. pole	10	16	25	35	50
4. pole PE	10	16	16	16	25

Any other assembly possible according to specifications.

Depending on the aisle length and the maximum delivery length of the conductor strips, the strips are commissioned assembly-ready ex works. The delivery of conductor strip rolls occurs according to weight, cross section and length in a pallet box or on a Europallet with shrink wrapping. The individual coils are prepared for the feed and are packaged for each aisle and delivered with pole and cross section information.

The delivery marking indicated is placed clearly visible on the outside in order to simplify the allocation of the different modules.

### Notes

- Depending on the conductor strip assembly, conductor length and change of the environmental temperature, expansion elements for the PVC profile may be necessary (see expansion elements page 15)
- see technical data for max. conductor and coil length



### Order No. 083214

Necessary order information

- aisle length
- conductor strip configuration  
e.g. 4 x 16 + 3 x 10 mm<sup>2</sup>
- delivery marking  
e.g. Storage Alpha LOG / Aisle 12

### Contents

- 4 to 7 conductor strips  
cross section and length according to customer specifications
- 4 to 7 connection cables to connect the power feed to the contact points of the construction. Number and cross section tailored to conductor assignment. Delivery length 1.5m standard, extra length according to customer specifications
- Including indication of assembly site  
e.g. Storage Alpha LOG / Aisle 12 (max. 40 characters)

### Note

Cables designed for max. environmental temperature of 35°C with nominal load.

Cables for higher environmental temperatures or cold storage applications upon request.



# Additional Modules

## System Hanger

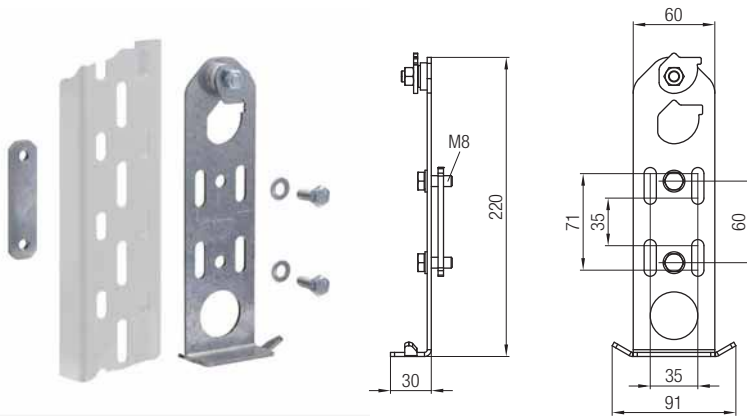

### Description

The clip-technique of the system hanger allows for quick assembly of the supporting section to the shelf structure. As an alternative to direct screwing, there are several adapters for building on floor supports, section supports or shelving stands to choose from. Feel free to contact us for more information about the continuously growing selection of adapters (see below for examples).

Order No.	Package Size [pc.]	Weight [kg/pac]
083246-73	5	1.85
Deliverable as multiple of the packaging size		

## Consoles

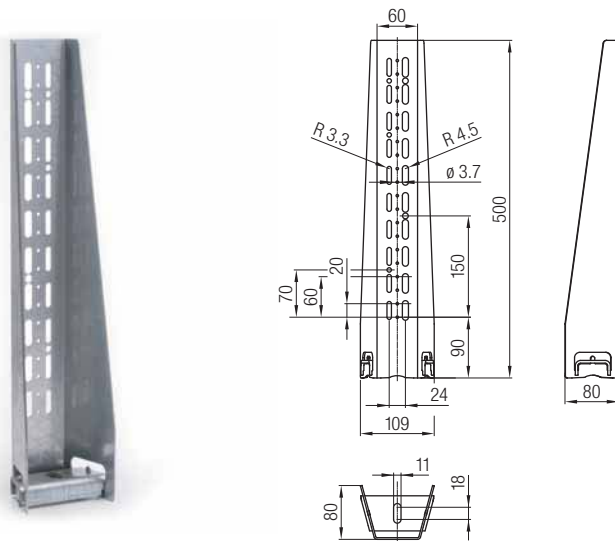

### Description

Consoles/ floor supports for quick one-hole assembly. Delivery including heavy-duty dowel M 10/10x90 and washer.

Order No.	Package Size [pc.]	Weight [kg/pac]
080043-11x11x01	5	9.5
Deliverable as multiple of the packaging size		

Spare Dowel: Order No. 41001

## Adapter

By combining the system hangers with several adapters on-site assembly of the structure can be further optimized. Semi-standard components and customer-specific design upon request.



# Additional Modules

## Positioning Module

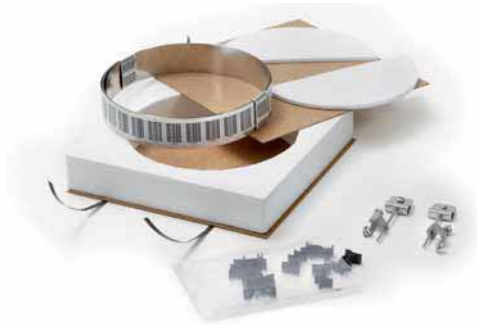

Positioning module

### Description

The positioning module allows for quick and flexible integration of the LEUZE bar code band for determining the position with the bar code readers BPS 34 and 37. The bar code band is fixed at the plant according to customer specifications on a stainless steel strip and fastened via clip holders and two tension elements onto the **EcoClickLine** – System. The assembly of the band with a width of 50 mm can occur during this below, above and with 4 to 6 pole systems also before the 7th pole. The module is assembled according to order and contains all of the components necessary for assembly at the supporting section of the conductor rail. The code band is automatically glued under ideal conditions in order to avoid line expansion and therefore also associated measurement errors. Due to the separation of the supporting section and the strip support assembly error corrections and code band repairs are simple and quick, especially in cool storage systems.

Order No.	Length [m]	Weight [kg/m]
080243-1	10 bis 150	0.08

Layout PO (below the support profile)

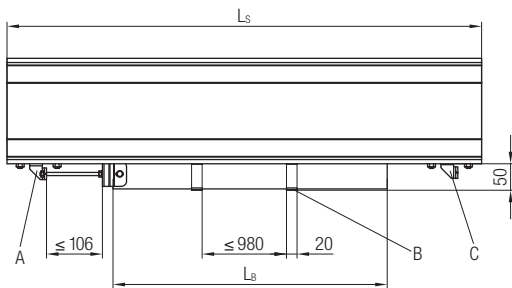

Layout PO (above the support profile)

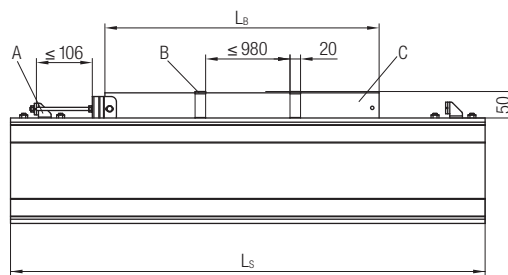

$L_B$  = Length of bar code strip |  $L_S$  = System length  
 A = Tension unit | B = Strip holder | C = Bar code band

Layout P7

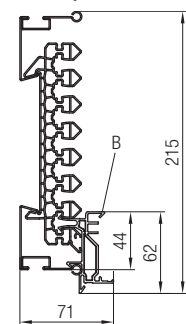

Code band and tension unit

### Content of the packaging unit

- 1 x stainless steel band 50 x 0.2 mm with applied code tape of up to 150 m in length
- 2 x tension unit for attachment to the supporting section as well as clip holders for guiding of the code band (1 piece per meter)
- Delivery includes indication of delivery marking / installation situation

### Necessary order information

- Installation position (above or below the supporting section = Layout PO, before 7 pole = Layout P7)
- Length of the code band
- Desired initial or final code
- Delivery marking e.g. Storage Alpha LOG / Aisle 12

### Notes

- Bar code reader not included in scope of delivery
- For positioning and installation position of the bar code reader please observe information and tolerances indicated by the manufacturer

## Overview of Bar Code Assembly

Assembled with Code Band <sup>1)</sup>	Length [m]	Standard coding	Special coding <sup>2)</sup>
BCB 020	20	ascending from 0	Start position according to specifications
BCB 030	30		
BCB 040 to 130	in a grid of 10 m		
BCB 150	150		

1) Code strip layout according to the product identification and specifications of the company Leuze electronic GmbH + Co. KG

2) Special coding upon request (beginning with a total quantity of 150 m, not on stock)

3) In-between length are possible e.g. 47 m (minimum order length 30 m)

The attachment set for the laminated strip of the positioning system WCS by Pepperl + Fuchs is available upon request.

# Additional Modules

## Funnel / Pick Up Guide

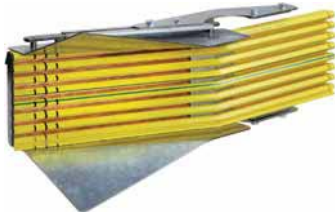

### Description

Entrance and exit aids for the current collector e.g. for building divisions or fire protection facilities

Order No.	Design	Max. speed [m/min]	Weight [kg]
083281-72x25x12 <sup>1)</sup>	left	80	5.5
083281-71x25x12 <sup>1)</sup>	right		5.5

<sup>1)</sup> available starting in 2009

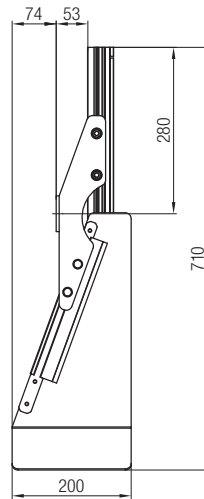
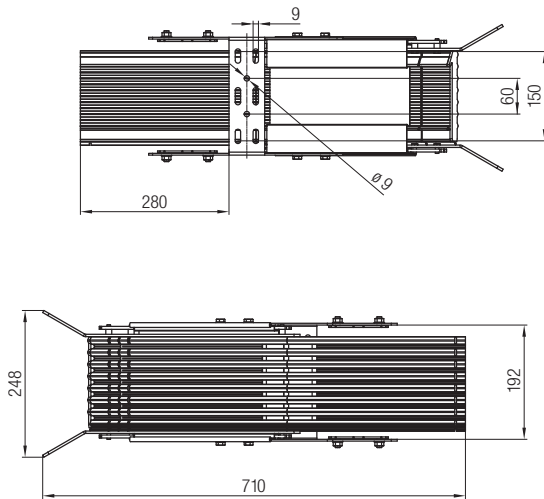

### Note

For tolerances and other project-related information, see the Technical Information: Funnel **EcoClickLine**

## Power Feed



### Description

For compensation of the potential difference or constructional sectioning of the aisles additional power feeds may be useful. The feed is integrated before the conductor strips are put in between the two insulating sections. The connecting line set is delivered ready for assembly according to pole assignment and line lengths. Flexible single wires L = 1.5 m + optional multiple lengths connect the feed with the contact points of the construction.

Order No.	Description	Weight [kg]
083252-710x12	feed 0832 7P	4.1

### Notes

- The basic module 0832 7P (083258-710x12) already includes a feed
- The connecting lines are to be ordered separately When ordering indicate quantity, cross section and length of the desired line
- When using 2 or more feeds the expansion behavior of the system in correlation to the layout and temperature changes must also be taken into consideration. Layout and project support upon request.

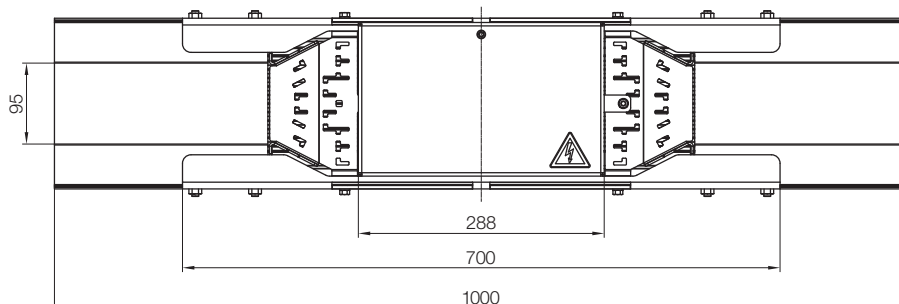
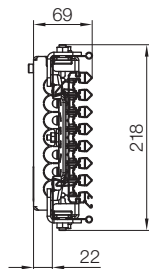

# Additional Modules

## Conductor Strip Connector

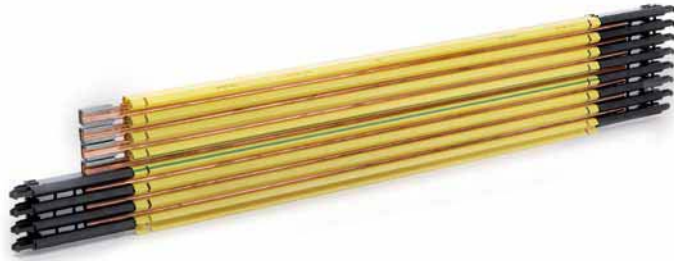

### Description

Module unit for connecting the conductor strips. Use for installations with system lengths exceeding the maximum roll length or for system extensions. The conductor assignment occurs according to customer specifications. Delivery including all connector parts as well as supporting frame for rear access to the connection joints.

Order No.	Rated Length [mm]	Weight [kg]
083221-31x7	1000	6.0 - 8.2

### Notes

- In order to make assembly easier it is recommended to use one expansion element mounted next to the connection joints.
- Access to the rear side is necessary at the connection joints

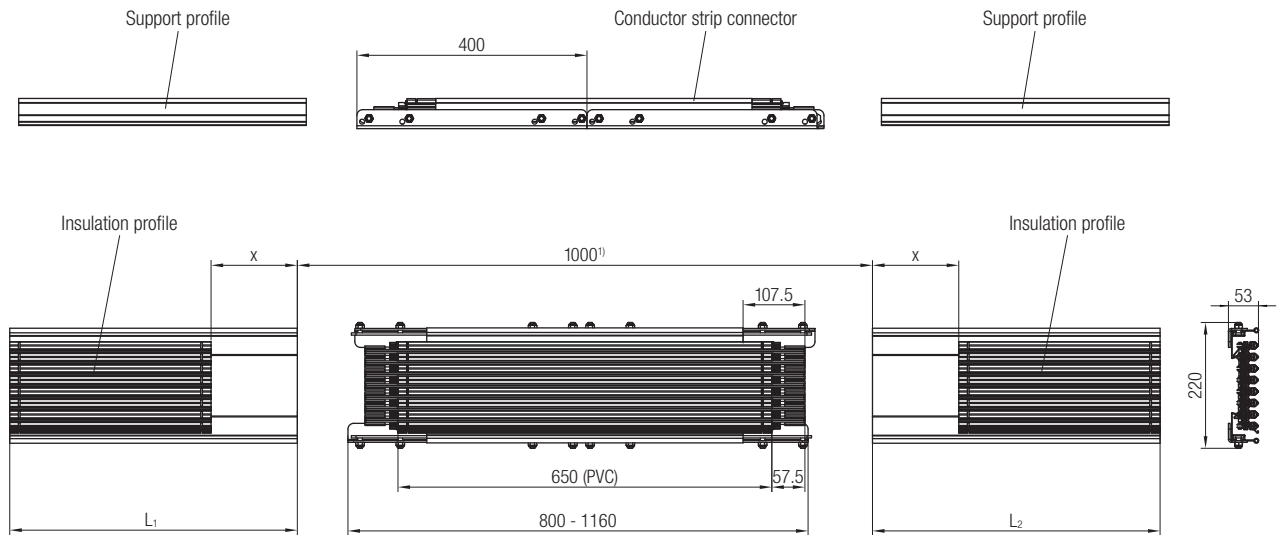

x = depending on assembly and operating temperatures

1) Distance of the assembled support sections



# Additional Modules

## Expansion Module



### Description

Unit to compensate the expansion of the insulation profiles during temperature changes. The expansion element is premounted and integrated as a standard insulation profiles.

Order No.	Description	Length [mm]	Expansion Distance [mm]	Weight [kg]
083266-2x07x12	expansion distance 0832 7P	1000 / 1080 <sup>1)</sup>	80	0.8

1) length extended

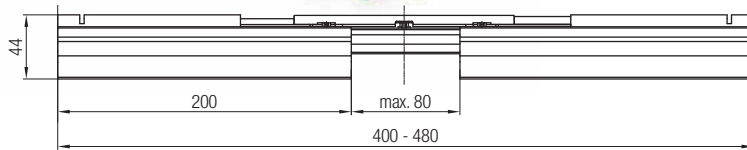

### Delivery

- 1 x support profile 1000 mm
- 1 x expansion element 400 mm
- 1 x PVC profile 200 mm
- 1 x PVC profile 400 mm
- Connecting material

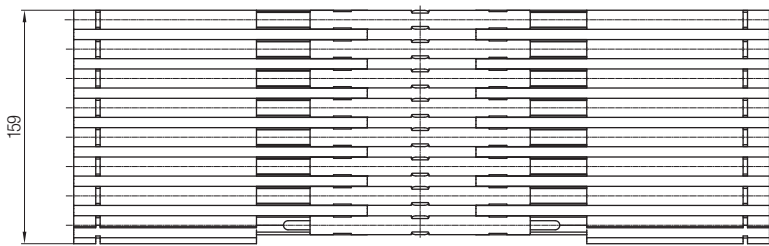

### Overview of the number of expansion elements required

Depending on a change in temperature and the length of the conductor strip lengths the expansion elements are to be included to compensate the different expansions. The table below shows the number of elements in correlation to the conductor strip assembly.

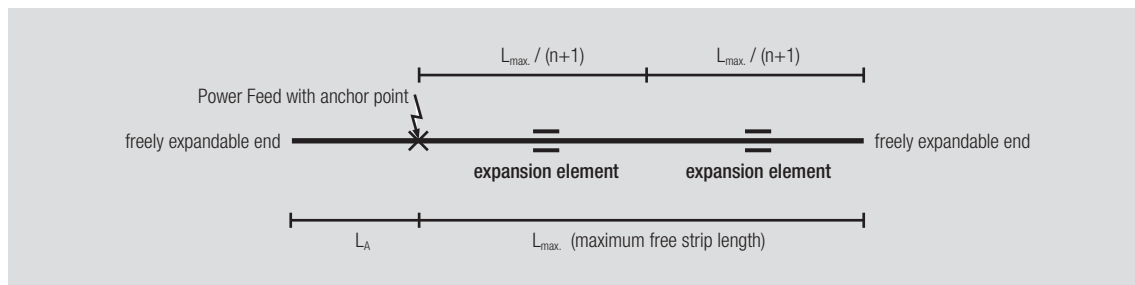

### Example

Aisle length ( $L_{ges}$ ): 105 m  
 Position of power feed ( $L_A$ ): 10 m offset  
 Conductor strip assembly: 7/25  
 Temperature difference: 20 K

### Test $L_A$ (step 1)

$L_A = 10$  m  
 Table with 20 k temperature difference  
 Line for configuration 7/25  
 $\Rightarrow L_{max} (10 \text{ m}) \leq 50$  m  
 $\Rightarrow n = 0$

### Test $L_{max}$ (step 2)

$L_{max} = L_{ges} - L_A$   
 $= 105 \text{ m} - 10 \text{ m}$   
 $= 95 \text{ m}$

Table with 20 k temperature difference  
 Line for configuration 7/25  
 $\Rightarrow L_{max} (95 \text{ m}) \leq 100$  m  
 $\Rightarrow n = 1$

### No. of Expansion Elements required

$n = 0 + 1 = 1$

Temperature difference	Configuration	Max. Free Strip Length $L_{max}$ [m]			
		n = 0	n = 1	n = 2	n = 3
20 k	7/10 and 7/16	$\leq 57$	$\leq 114$	$\leq 150$	-
	7/25	$\leq 50$	$\leq 100$	$\leq 150$	-
	7/35	$\leq 35$	$\leq 70$	$\leq 105$	$\leq 140$
	7/50	$\leq 30$	$\leq 60$	$\leq 90$	$\leq 120$
30 k	7/10 and 7/16	$\leq 38$	$\leq 76$	$\leq 114$	$\leq 150$
	7/25	$\leq 38$	$\leq 76$	$\leq 114$	$\leq 150$
	7/35	$\leq 35$	$\leq 70$	$\leq 100$	$\leq 140$
	7/50	$\leq 30$	$\leq 60$	$\leq 80$	-
50 k	7/10 and 7/16	$\leq 23$	$\leq 46$	$\leq 69$	$\leq 92$
	7/25	$\leq 23$	$\leq 46$	$\leq 69$	$\leq 92$
	7/35	$\leq 23$	$\leq 46$	$\leq 69$	$\leq 92$
	7/50	$\leq 23$	$\leq 46$	$\leq 69$	$\leq 92$

Conductor strip configuration see page 12

n = no. of expansion elements required

# Current Collector

## Current Collector 2 x 80A



### Description

Current collector unit including highly flexible connection cables wired to strip terminals at the assembly section. For easy and quick service, a change support is available (see below).

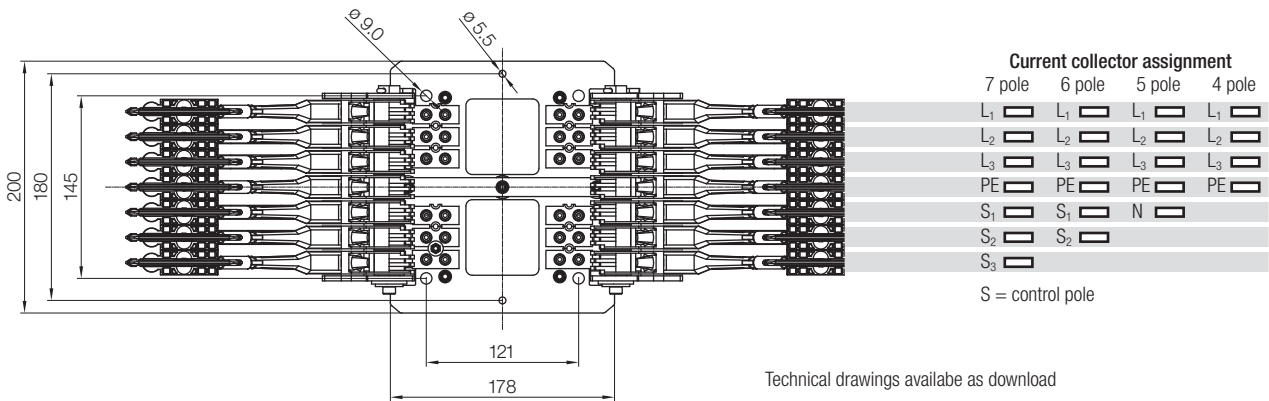
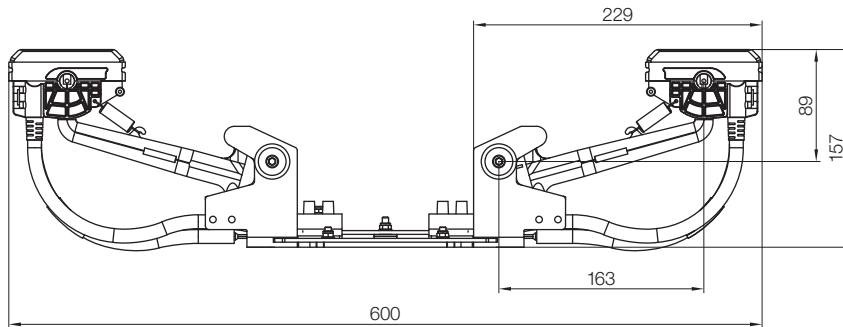

Technical drawings available as download

Order No.	Description	Number of Terminals	Rated Current [A]	Connection Cross Section	PE	No. of Poles	Weight [kg]
083204-0710420	current collector 0832 7P 2 x 80A	2 per pole	2 x 80	16 mm <sup>2</sup> (fine strand) 25 mm <sup>2</sup> (massive)	on Item 4 (from above)	7	8.6
083204-0610420	current collector 0832 6P 2 x 80A					6	7.6
083204-0510420	current collector 0832 5P 2 x 80A					5	6.6
083204-0410420	current collector 0832 4P 2 x 80A					4	5.6

## Change Support for Current Collector 1 x 80A and 2 x 80A

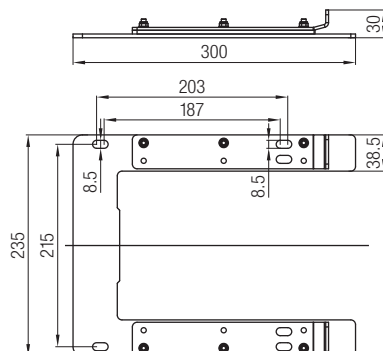

### Description

Change support for quick and easy service.

Order No.	Weight [kg]
083051	1.5

### Delivery

- Frame/ change support
- Access including lock to attach to the current collector unit (not illustrated)

Technical drawings available as download

# Current Collector

## Current Collector 1 x 80A



Design LE (left)

### Description

Current collector unit including highly flexible connection cables wired to strip terminals at the assembly section.

### Note

For use of the current collector 083203 with the change support 083251 the adapter Order No. 08-B020-6755 is required.

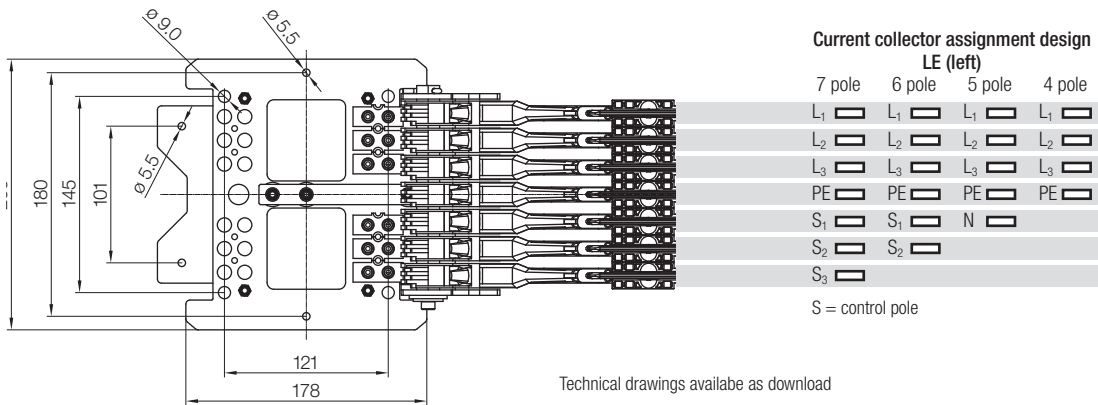
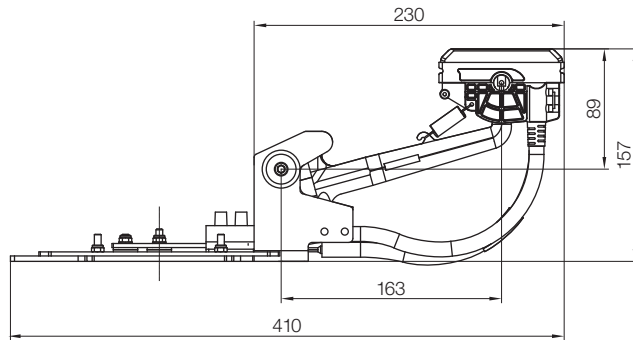

Technical drawings available as download

Order No.	Description	Design	Number of Terminals	Rated Current [A]	Connection Cross Section	No. of Poles	Weight [kg]
083203-0740420	current collector 0832 7P 1x 80A LE	LE	1 per pole	1 x 80	16 mm <sup>2</sup> (fine strand) 25 mm <sup>2</sup> (massive)	7	5.2
083203-0640420	current collector 0832 6P 1x 80A LE					6	4.7
083203-0540420	current collector 0832 5P 1x 80A LE					5	4.1
083203-0440420	current collector 0832 4P 1x 80A LE					4	3.6
083203-0650420	current collector 0832 6P 1x 80A RI	RI				6	4.7
083203-0550420	current collector 0832 5P 1x 80A RI					5	4.1
083203-0450420	current collector 0832 4P 1x 80A RI					4	3.6
08-B020-6755	adapter for exchange support	-	-	-	-	-	0.2

# Tools and Assembly Aids

## General Information

**EcoClickLine** is designed for assembly that for the most part is tool free and can be performed by one person. For several assembly steps the support of a second person is recommended. The tools and aids required for efficient assembly are available in 2 versions. For the assembly of several aisles or lengths >20m the use of an uncoil device (Tool set PROF) is recommended.

## Tool Set STANDARD and PROF



### Description

The tool set include aids that are required for quick material installation and effective assembly.



	STANDARD	PROFI	Remarks / Use
<b>Order No.</b>	<b>08-W100-0589</b>	<b>08-W100-0590</b>	
Dimensions			
Gross Weight			
<b>Content</b>			
Uncoil Device 0832	-	•	for uncoiling and support the conductor strips
Straightening Device 0832	•	•	for sighting in the conductor strips
Feed in Aid 0832	•	2 pieces	for manual feeding of the strip
Small Parts Service Package	•	•	connectors, pins, nuts, etc.
Transport Roller Set	-	•	transport aid for 24m module in the aisle
Saw Jig	•	•	use of PVC insulation profiles
Disassembly Tool PVC	•	•	separation PVC connector (set = 2 pcs.)
Ratchet/ Flat Wrench 13 mm Wrench Size	-	•	system hanger / uncoil device / supporting section
Transport Box	-	•	tool storage



# Wear and Spare Parts

## Repair Module



### Description

Repair module for the exchange of a part of the conductor rail system. Accident damage can therefore be quickly eliminated despite the continuous conductor strips. For the exchange of longer row sections, the module can be extended with standard modules e.g. Expansion Module 4 m and conductor strips sections.

Order No.	Weight [kg]
083222-31x7	28

### Content

- 1 x support profile with assembly frame
- 1 x insulation profiles with connection units
- 1 x expansion element
- 7 x conductor strip sections
- 1 x set of disassembly tools for PVC connector

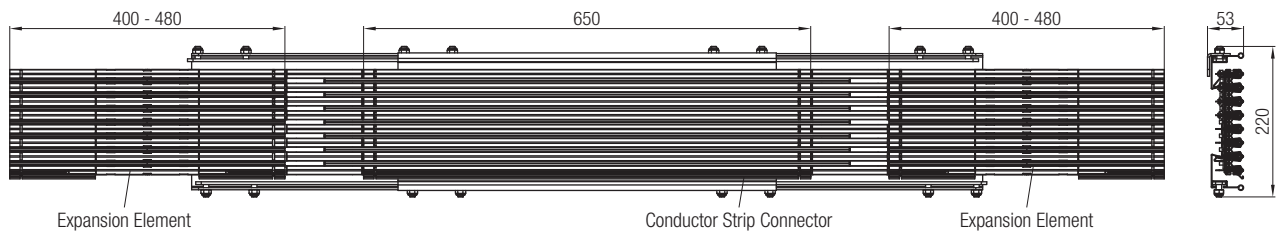

## Small Parts Service Package



### Description

Spare part package with all of the small parts and assembly parts required in the standard system for simple assembly use. The small parts service package is a part of the basic module and tool sets.

Order No.	Weight [kg]
08-B055-0006	0,4

### Content

- 2 x clamps
- 10 x Connecting pins for the supporting section
- 12 x Connectors for the insulation profiles (4 part component)
- 2 x grub screws feed/ Cu- connector
- 10 x nut M8 with integrated washer
- 1 x assembly instructions / spare part use

## Current Collector - Spare Parts



### Description

For simple and safe exchange there are complete current collector heads available including highly flexible connecting cables. Brush changing according to specifications only possible together with the cable (safety-relevant wear part).

Order No.	Spare Heads Complete	Pole Number	Weight [kg]
083003-0x47	(SET) 6 x 2 PH + 1 x 2 PE	7	2.1
083003-1x41	1 x PH	1	0.1
083003-2x41	1 x PE		

### Note

PE spare head cannot be used for phase (wrong placement safety provided)

### Current Collector Arm without Head

Order No.			
08-S265-2001	1 x PH	1	0.4
08-S265-2002	1 x PE		

# Wear and Spare Parts

## End Cap

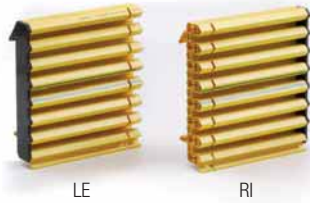

### Description

End cap for termination and contact protection at the end of the insulation profile. Delivery includes insulating connectors.

Order No.	Design	Weight [kg]
083271-7	RI (right)	0.3
083272-7	LE (left)	

## Insulating Connector



### Description

Connector components for insulation profile.

Order No.	Weight [kg]
083229-10x7	0.2

### Content

12 x 4-part component (sufficient for 6 section connections)

## Connector Set



### Description

Connector set for a system connection (support and insulation profile).

Order No.	Weight [kg]
083229-31x0	0.2

### Contents

- 2 x clamps complete
- 2 x centering pins
- 2 x 4-part component insulating connectors

## Insulation and Support Profiles



### Description

Insulating and supporting section segments for replacement requirements.

Order No.	Design		Weight [kg]
	Profile	Length [m]	
083210-001x7x12	Insulation profile 0832	1	1.5
083210-004x7x12	Insulation profile 0832	4	6.1
083210-001x7x40	Support profile 0832	1	3.3
083210-004x7x40	Support profile 0832	4	13.2

## Bar Code Band - Spare Parts



### Description

Components for the replacement and/or equipping of an alternative installation position.

Order No.	Design	Weight [kg]
08-H016-0257	Bar code band holder package unit with 20 pcs	0.2
08-S008-0303	Tension set for assembly version P0	0.3
08-S008-0304	Tension set for assembly version P7	0.6

# System

## System Dimensions / Installation Instructions

Sketch of supporting section

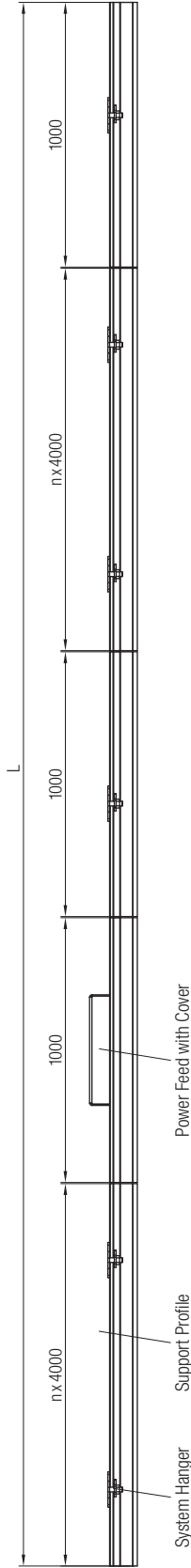

Sketch of insulating section

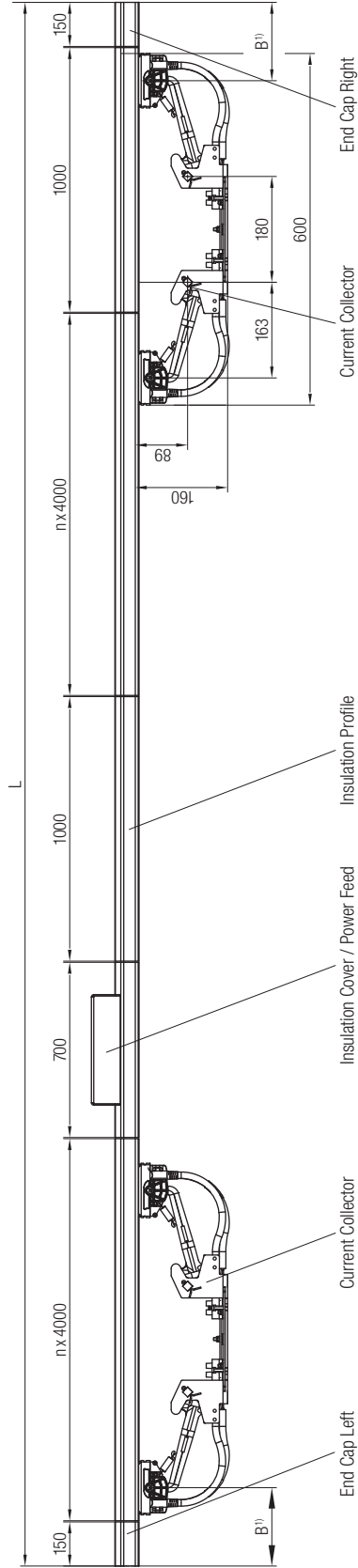

1) min. 200 + expansion distance

Nominal Offset PVC and Supporting Section joint

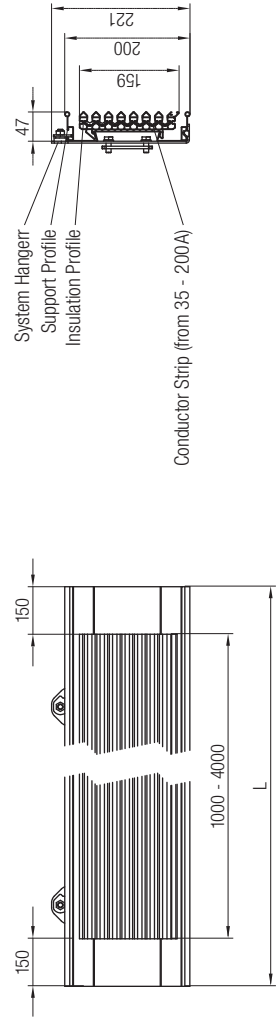

# Frequently Asked Questions

---

## Up to what length can the system be used?

Theoretically the system can be expanded to any length. For lengths of more than the maximum coil length of the conductor strips, the conductor strip connectors as well as additional expansion elements may be necessary. The coil lengths have been designed for practical handling and coverage of the most frequently used aisle lengths. For conductor cross sections of less than 50 mm<sup>2</sup> lengths of 100 m and more are possible. In connection with a conductor strip connection aisles with 50 mm<sup>2</sup> and 160 m are possible.

---

## Can the system also be built vertically at the pole?

The system has been designed for horizontal assembly and uses this to its benefit. Vertical assembly is possible with cut backs (upon request). For vertical installation e.g. at the AS/RS crane, conductor rail system 0831 is technically better suited in design as a connector system.

---

## Can this be used in cold storage warehouses and can the same components be used here?

The system can be used also for cold storage systems. Several points such as additional expansion elements are to be taken into consideration during selection and assembly (see technical guidelines and operating instructions).

---

## Can the system be used also without the supporting section in order to save costs?

The system has been designed so that the supporting and insulating sections work together and they should not be used separately. Omitting the supporting section causes assembly costs to increase and at the same time limits the essential advantages of the system.

---

## Can the modules also be bought in individual parts?

The module concept allows for standardization. Separating the module means more expense and higher system costs. Individual parts can be purchased as spare parts.

---

## Is it possible to mount the system hanging (with operation going downward) - e.g. under the ceiling of the hall?

The system has been designed for lateral operation with simple clip-in assembly for the insulating section. Assembly with operation from below requires additional securing of the system. As of early 2008, the system has not been released yet for this type of installation position. The extra charges for the feed (depending on the height of the assembly) are also to be taken into consideration here.

---

## Is it possible to buy the system also as a 4 or 5 pole system?

A pole number of 7 covers the requirements of current and future AS/RS cranes applications. Equipping the system with 4, 5 or 6 lines is possible.

---

## Is parallel switching of the conductors possible?

Parallel switching of the conductors is only allowed to reduce the potential difference. Parallel switching to increase the current is controversial from an engineering perspective especially with regard to insurance and is therefore not permitted as a general rule. Irrespective of whether it is permitted or not, lines and conductor rails are to be fused in such a manner that in the event that one conductor is defect the remaining cross section is not overloaded. When fusing the conductor rails it should also be taken into consideration that this does not involve a fixed connection between current collector and conductor rail and that these contact points can vary greatly with regard to their quality, depending on age and environmental factors.

---

## Can the system be repaired after an accident?

Yes. Repair with a repair kit as well as extension with a connector is possible.

---

## Which tools are required for assembly?

The system has been created in such a way that it is self-explanatory and few tools are needed. Only one screw wrench (wrench size 13) is needed as a tool for the screw connections. For the feed of the conductor strips a uncoil device with aligning tool as well as feed aid are available. These tools can be bought or leased.

---

## What is the maximum assembly distance of the system?

The system can have a maximum distance of 4 m. The recommended distance is between 2.5 and 3.2 m. This value is based on a mean load of 100 kg or 1000 N. It is possible to extend the system by limiting the weight load. A typical distance selected for pallet storage is often a distance of 3.2 m for 3 Europallets (net 800 mm).

---

## Are there also conductor strip materials other than copper?

The system has been designed as standard for copper strips of up to a nominal cross section of 50 mm<sup>2</sup>. Other conducting materials are available upon request.

---

## Which nominal cross sections are available?

5 cross sections are available for the system: 10, 16, 25, 30 and 50 mm<sup>2</sup>

---

## Can the system also be delivered curved?

The system is designed for straight strips. If necessary other programs can be used.



# Questionnaire

If you would like us to make you an offer, please fill out the following information: If you have any questions please do not hesitate to contact a sales representative.

## General project information

Project: \_\_\_\_\_  
 \_\_\_\_\_  
 \_\_\_\_\_  
 \_\_\_\_\_  
 \_\_\_\_\_  
 \_\_\_\_\_

Number: \_\_\_\_\_ aisles      Length: \_\_\_\_\_ m

### Configuration

Pole	10 mm <sup>2</sup>	20 mm <sup>2</sup>	30 mm <sup>2</sup>	40 mm <sup>2</sup>	50 mm <sup>2</sup>
1	<input type="checkbox"/>	<input type="checkbox"/>	<input type="checkbox"/>	<input type="checkbox"/>	<input type="checkbox"/>
2	<input type="checkbox"/>	<input type="checkbox"/>	<input type="checkbox"/>	<input type="checkbox"/>	<input type="checkbox"/>
3	<input type="checkbox"/>	<input type="checkbox"/>	<input type="checkbox"/>	<input type="checkbox"/>	<input type="checkbox"/>
PE	<input type="checkbox"/>	<input type="checkbox"/>	<input type="checkbox"/>	<input type="checkbox"/>	<input type="checkbox"/>
5	<input type="checkbox"/>	<input type="checkbox"/>	<input type="checkbox"/>	<input type="checkbox"/>	<input type="checkbox"/>
6	<input type="checkbox"/>	<input type="checkbox"/>	<input type="checkbox"/>	<input type="checkbox"/>	<input type="checkbox"/>
7	<input type="checkbox"/>	<input type="checkbox"/>	<input type="checkbox"/>	<input type="checkbox"/>	<input type="checkbox"/>

Number: \_\_\_\_\_ aisles      Length: \_\_\_\_\_ m

### Configuration

Pole	10 mm <sup>2</sup>	20 mm <sup>2</sup>	30 mm <sup>2</sup>	40 mm <sup>2</sup>	50 mm <sup>2</sup>
1	<input type="checkbox"/>	<input type="checkbox"/>	<input type="checkbox"/>	<input type="checkbox"/>	<input type="checkbox"/>
2	<input type="checkbox"/>	<input type="checkbox"/>	<input type="checkbox"/>	<input type="checkbox"/>	<input type="checkbox"/>
3	<input type="checkbox"/>	<input type="checkbox"/>	<input type="checkbox"/>	<input type="checkbox"/>	<input type="checkbox"/>
PE	<input type="checkbox"/>	<input type="checkbox"/>	<input type="checkbox"/>	<input type="checkbox"/>	<input type="checkbox"/>
5	<input type="checkbox"/>	<input type="checkbox"/>	<input type="checkbox"/>	<input type="checkbox"/>	<input type="checkbox"/>
6	<input type="checkbox"/>	<input type="checkbox"/>	<input type="checkbox"/>	<input type="checkbox"/>	<input type="checkbox"/>
7	<input type="checkbox"/>	<input type="checkbox"/>	<input type="checkbox"/>	<input type="checkbox"/>	<input type="checkbox"/>

### Environmental Temperature Range

+10 ... +35°C  
 \_\_\_\_\_ °C to \_\_\_\_\_ °C       Cold storage

### Installation Position

In the floor area lateral access (standard)      Height lower edge \_\_\_\_\_ mm  
 \_\_\_\_\_

### Installation

Floor supports  
 Shelf assembly  
 \_\_\_\_\_

## Electrical Parameters

• Operational voltage       3 Ph 400 VAC  
 \_\_\_\_\_  
 • Supply frequency       50 Hz       60 Hz  
 • Mean current load      \_\_\_\_\_ A  
 • AS/RS mode of operation       S \_\_\_\_\_ / \_\_\_\_\_ %  
 • Drive performance per AS/RS crane      \_\_\_\_\_ kW  
 • Max. permissible voltage drop       5 %       \_\_\_\_\_ %  
 \_\_\_\_\_ V

## Feed

1 x system power feed  
 (1 m to L/2 from aisle end)  
 \_\_\_\_\_ additional power feeds

## Number of Consumer Loads / Current Collector Type

1 x RBG       2 x RBG      No. of current collectors per RBG \_\_\_\_\_  
 Double current collectors 2 x 80 A       with change support  
 Single current collector 1 x 80 A       with change support  
 \_\_\_\_\_

## Options/ other System Requirements

Dividers e.g. Fire vents or gates  
 Converters or curve goers  
 Leuze BPS coding strip option (please indicate coding, see below)  
 WCS –Laminate strip (Pepperl+Fuchs)

## Assembly Performed

by customer  
 by Conductix-Wampller Service

## Assembly Tools

EcoClickLine tool set existing  
 Offer tools for sale  
 Leasing of tool set desired

## Additional Information; e.g. Coding

\_\_\_\_\_  
 \_\_\_\_\_  
 \_\_\_\_\_  
 \_\_\_\_\_  
 \_\_\_\_\_  
 \_\_\_\_\_

## Please mail your offer to the following address

Company: \_\_\_\_\_      Cust. No.: \_\_\_\_\_  
 Dept./ Attn: \_\_\_\_\_  
 Address: \_\_\_\_\_  
 \_\_\_\_\_  
 \_\_\_\_\_  
 Phone: \_\_\_\_\_      Fax: \_\_\_\_\_  
 Email: \_\_\_\_\_

# Tailored Service

## Would you like a bit more?

When it comes to conductor rail systems, we think of more! Regardless of whether you want information, a solution for your task or on-site support. We speak your language. Feel free to contact us! We've got your solution.

## Project management

- Admission of the assignment list and engineering of the system

## Consignment sale and pre-assembly

- Pre-assembly and assembly-oriented packaging
- Pre-built material transport up to the storage aisle

## Assembly and commissioning

- Installation, commissioning and instruction by a specialist up to handover to the customer



## Leasing service and supervisor

- Provision of the assembly facilities and special tools for efficient assembly of our systems
- Upon request also support by an experienced supervisor from our service team

## Maintenance & Service

- Regular inspections of the system, exchange of wear parts, cleaning and testing
- Assembly and maintenance training
- Supervising



From project management, to pre-assembly up to on-site installation. Conductix-Wampfler specialists will accompany you all over the world!



# Your Applications | our Solutions

Conductor rail systems from Conductix-Wampfler represent only one of the many solutions made possible by the broad spectrum of Conductix-Wampfler components for the transport of energy and data. The solutions we deliver for your applications are of course based on your specific requirements.

In many cases, a combination of several different Conductix-Wampfler systems can prove advantageous.

You can count on all of Conductix-Wampfler's Market Units for hands-on engineering support - coupled with the perfect solution to meet your energy management and control needs.



## Festoon systems

It is hard to imagine Conductix-Wampfler cable trolleys not being used in virtually every industrial application: They're reliable and robust in an enormous variety of dimensions and designs.

## Cable reels

Motorized and spring cable reels by Conductix-Wampfler are proven solutions wherever energy, data and media have to cover the most diverse distances within a short amount of time - in all directions, fast and safe.

## Slip ring bodies

Whenever things are really moving "in circles", the proven slip ring bodies by Conductix-Wampfler ensure the flawless transfer of energy and data. Here, everything revolves around flexibility and reliability!

## Conductor rails

Whether they're enclosed conductor rails or expandable single-pole systems, the proven conductor rails by Conductix-Wampfler reliably move people and material.

## Energy guiding chains

The „Jack of all trades“ when it comes to transferring energy, data and media. This broad range of energy guiding chains are proven performers in industrial applications.

## Inductive Power Transfer IPT®

The non-contact system for transferring energy and data. For all tasks that depend on high speeds and absolute resistance to wear.

# www.conductix.com

---

**Conductix-Wampfler GmbH**

Rheinstrasse 27+33  
79576 Weil am Rhein  
Germany

Hotline

Phone +49 (0) 7621 662-222

Phone +49 (0) 7621 662-0

Fax +49 (0) 7621 662-144

info.de@conductix.com

www.conductix.com



Ⓞ DELACHAUX GROUP