

1

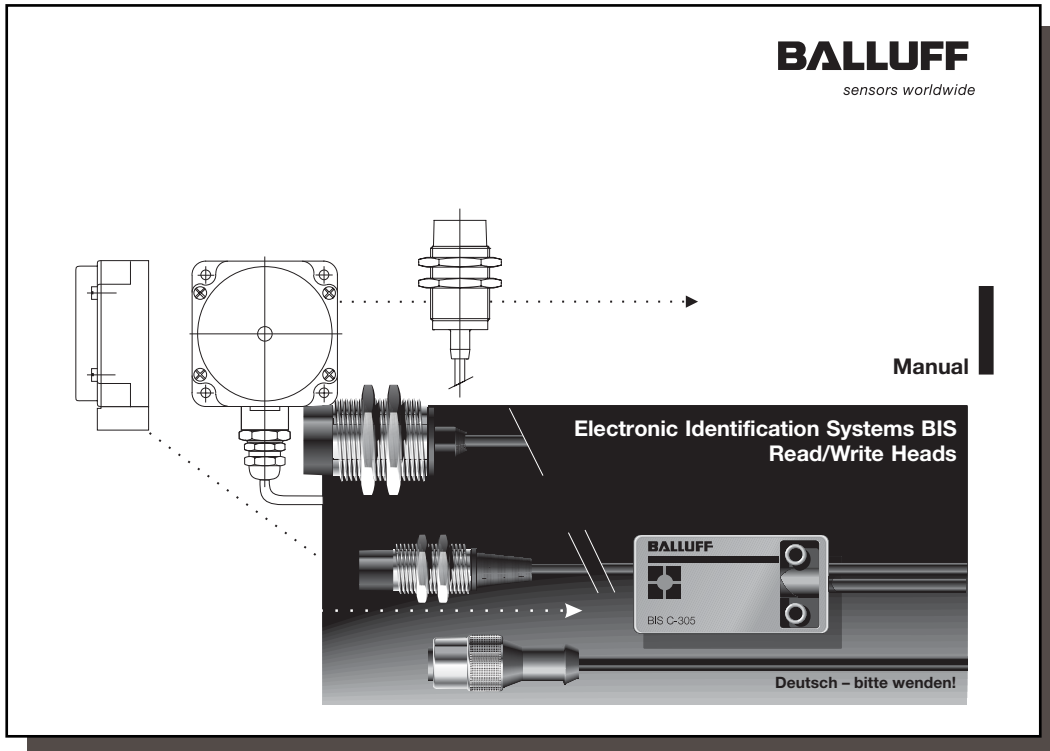

2

No. 716 464 D/E • Edition 1110
Subject to modification.
Replaces edition 1104.

Balluff GmbH
Schurwaldstrasse 9
73765 Neuhausen a.d.F.
Germany
Phone +49 7158 173-0
Fax +49 7158 5010
balluff@balluff.de

■ www.balluff.com

Contents

Safety Considerations	4
Introduction BIS C Identification System	5
Interaction Read/Write Heads and Data Carrier	7
Selection Criteria Read/Write Heads Series BIS C-3_	10
Installation in Aluminum	14/15
Read/Write Head BIS C-300-__	16
Read/Write Head BIS C-306-__	17
Read/Write Head BIS C-302-__	18
Read/Write Head BIS C-305-__	19
Read/Write Head BIS C-319-__	20
Read/Write Head BIS C-326-__	21
Read/Write Head BIS C-315-__	22
Read/Write Head BIS C-310-__	23
Read/Write Head BIS C-319/_-S4	24
Read/Write Head BIS C-315/_-S4	25
Read/Write Head BIS C-323/_-S4	26
Read/Write Head BIS C-324/_-S4	28
Read/Write Head BIS C-325/_-S4	30
Read/Write Head BIS C-328/_-S49	31
Read/Write Head BIS C-327	32
Read/Write Head BIS C-318-__	33
Read/Write Head BIS C-351-__	34
Read/Write Head BIS C-350-00,3	35
Read/Write Head BIS C-355/05-S92	36
Wiring Diagram	37
Connection Cable for Read/Write Heads with S4 Connectors	38
Technical Information	40

Safety Considerations

Series BIS C-3_ _ processors along with the other BIS C system components comprise an identification system and may only be used for this purpose in an industrial environment in conformity with Class A of the EMC Law.

Installation and Operation

Installation and operation should be done by trained personnel only. Unauthorized access and improper use will lead to loss of warranty and guaranty.

When installing the read/write heads, pay close attention to the section containing connection diagrams.

Use and Checking

When using the Identification System, standard safety practices should be adhered to. In particular, measures must be taken to ensure that in case of failure of the Identification System no danger to persons or property can arise.

This includes maintaining the published ambient conditions and regular checking of the functionality of the Identification System with all the components associated with, and keeping inspection records.

Fault Conditions

If there is evidence that the Identification System is not operating properly, it should be taken out of service and protected from unauthorized use.

Validity

This description is valid for read/write heads in series BIS C-3_ _.

Introduction BIS C Identification System

This handbook is intended to guide the user during installation and startup of the components in the Identification System BIS C so that it can be brought into operation with a minimum of time and effort.

Principle

The Identification System BIS C belongs to the category of

non-contact operating systems which can be read as well as programmed.

This dual function permits applications in which not only fixed programmed information can be transported, but also up-to-date information can be collected on the data carrier and carried with it during the process.

Applications

A few of the more notable applications include

- **in manufacturing for controlling material flow**
e.g. in model-specific processes,
in workpiece transport with conveying lines,
for data gathering in quality assurance,
for gathering safety-relevant data,
- **tool coding and monitoring**
- **Production equipment organization;**
- **inventory for monitoring stock movement and levels,**
- **conveying and transporting technology,**
- **waste collection for quantity-based billing.**

Introduction BIS C Identification System

System Components

The main components of the BIS C Identification System are:

- Processor,
- Read/Write Heads and
- Data carrier.

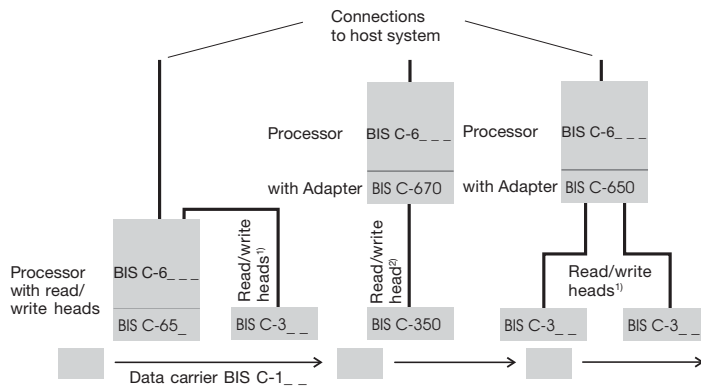

Schematic representation of an identification system (example)

¹⁾ except BIS C-350 and -355

²⁾ only BIS C-350

7

Interaction Read/Write Heads and Data Carrier

Spatial Arrangement of Read/Write Head and Data Carrier

The key to reliable data exchange between the read/write head and the data carrier is maintaining sufficient dwell time of the data carrier within a specified spatial distance from the read/write head. The sketches on the two following pages are intended to clarify this requirement, in the first sketch for read/write heads with non-directional operation, in the second for read/write heads in cases where the data carriers have to pass by from a certain direction or at a certain orientation.

In **static read/write operation** the data carrier stops completely in front of the read/write head during the read/write process; this permits a greater distance between the two.

In **dynamic operation** the data carrier is read or programmed on the fly. A shorter distance is necessary in order to achieve as large a read/write range as possible.

Each read/write head has certain data carriers which can be used with it (the pairing is based on physical size and antenna field configuration). The associated specifications for distance and permissible offset are indicated as well as the distance and relative speed between the read/write head and the data carrier.

english | BALLUFF | 7

8

Interaction Read/Write Heads and Data Carrier

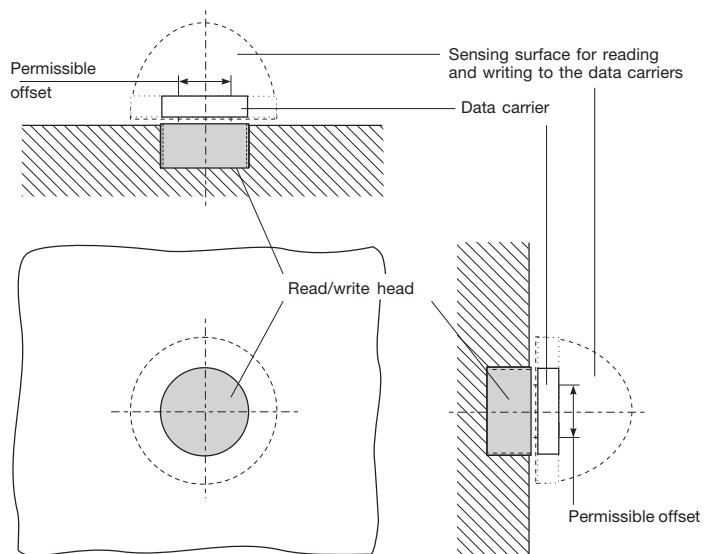

*Spatial arrangement of
Read/Write Head and
Data Carrier for non-
directional Read/Write
Heads and flush
mounting (circular
antenna)*

8 | BALLUFF | english

Interaction Read/Write Heads and Data Carrier

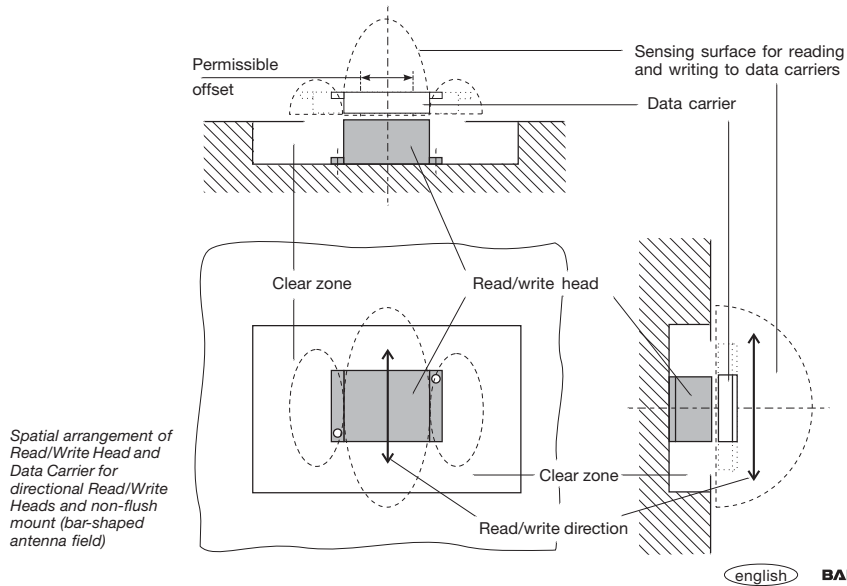

Selection Criteria Read/Write Heads Series BIS C-3_ _

Connection cable for Read/Write Heads

The cable length of the read/write heads may not be altered.
Exception: Read/Write Head BIS C-350-00,3.

Bending radius for cable

The cable connecting the read/write heads must maintain a least bending radius.
The least bending radius for PVC jacketed cable is 26 mm when static and 52 mm when dynamic.
The least bending radius for PU jacketed cable is 20 mm.
The special PU1 cable for continuously dynamic use requires a least bending radius of 34 mm.

Selection of Read/Write Head

All read/write heads can be used for static and dynamic reading (and writing). When selecting the optimal read/write Head, the following factors must be taken into consideration:
Mounting conditions, method of attachment and size, read/write distance.

Please use the following tables for orientation with respect to

- size,
- enclosure rating,
- attachment possibilities,
- distances,
- direction of approach and
- wiring considerations.

Selection Criteria Read/Write Heads Series BIS C-3_ _

Tabular Overview

The table lists read/write heads which can be flush **mounted in steel**. For notes on installing in aluminium, see ¶ 14. The read/write orientation may be any, since a round antenna form is used for these read/write heads.

Criteria	Types: ¹⁾ BIS C-300-__	C-306-__	C-302-__	C-305-__	C-315-__	C-325/_-S4	C-324/_-S4
Size	[mm] Ø 14.5 × 55	M16×1 × 55	61.5 × 33 × 40	50 × 25 × 10	80 × 80 × 40	M18×1 × 45	40 × 41 × 74.5
Distance ²⁾	[mm]	32	32	40	180	60	60
Enclosure per IEC 60529	IP 67						
Housing material	CuZn Nickel plated	Brass Nickel plated	Al Mg3 / PA66	ABS-GF16	Plastic PBT	X6CrNiMoTi 17-12-2	Plastic PBT
Mounting 2 nuts SW Screws	secure in slot	22	2 × M4	2 × M4	4 × M5	24	2 × M5
Connection to the BIS C-6-__	direct, using molded-on connection cable with 4-pin connector					using a connection cable ³⁾	
Cable length ¹⁾	[m]	1, 5, 10	1, 5, 10	5, 10	1, 5, 10	1, 5, 10	5, 10
Cable material		PU	PU	PVC/PU	PVC/PU	³⁾	³⁾
Temperature	Ambient 0 °C to +70 °C / storage -20 °C to +85 °C						
Weight	[g]	210	200	270	230	510	26

¹⁾ in the part number for read/write head, __ is for inserting the desired cable length: 01 = 1 m, 05 = 5 m, 10 = 10 m
²⁾ The distance is defined as free space between two read/write heads of equal size. When the two read/write heads differ in size or when the data carrier is larger than the read/write head, the distance of the larger device has to be applied.
³⁾ appropriate connector cable: BIS C-505-PU-__ / BIS C-506-PU-__ / BIS C-517-PVC-__ / BIS C-518-PVC-__
 For details, see ordering information for cable and connectors

Selection Criteria Read/Write Heads Series BIS C-3_ _

Tabular Overview

The table lists read/write heads which cannot be flush **mounted in steel**. For notes on installing in aluminium, see ¶ 14.

Criteria	Types: ¹⁾ BIS C-319/_-S4	C-323/_-S4	C-315/_-S4	C-319-__	C-326-__	C-310-__	C-318-__	C-351-__	C-355/05-S92	C-350-00,3	
Size	[mm] M18×1 × 86.5	M30×1.5 × 70.5	80 × 106 × 40	M18×1 × 80	M30×1.5 × 83.5	M30×1.5 × 70	186 × 48 × 30	170 × 80	240 × 120 × 60	240 × 120 × 60	
Read/write orientation	non-directional							directional			
Antenna form	round							Bar	Bar ²⁾	Bar	
Distance ³⁾	[mm]	180	180	180	180	60	60	1000	1000	2000	
Enclosure per DIN 40 050	IP 67							IP 65		IP 67	
Housing material	Plastic PBT	X6CrNiS 18-9	Plastic PBT	Plastic PBT	Plastic PVDF	CuZn Nickel plated	Plastic PA66	Polyacetat	Plastic PC	Plastic PC	
Mounting 2 nuts SW Screws	24	36	4 × M5	24	36	4 × M5	4 × M6	4 × M4	4 × M4		
Connection to the BIS C-6-__	using a connection cable ⁴⁾			direct, using molded-on connection cable with 4-pin connector				⁵⁾	⁶⁾		
Cable length	[m]	1, 5, 10	5, 10	5, 10	1, 5, 10	5, 10	1, 5, 10	5, 10	5	0.3	
Cable material		⁴⁾	⁴⁾	⁴⁾	PU	PU	PU	PU	⁵⁾	PU	
Temperature ambient storage	[°C]	0 to +70 -20 to +85							0 to +70 -20 to +85		0 to +40 -20 to +85
Weight	[g]	40	90	410	197	270	314	550	595	710	

¹⁾ In the part number for read/write heads, __ is for inserting the desired cable length: 01 = 1 m, 05 = 5 m, 10 = 10 m
²⁾ Double antenna for increased traverse speed
³⁾ The distance is defined as free space between two read/write heads of equal size. When the two read/write heads differ in size or when the data carrier is larger than the read/write head, the distance of the larger device has to be applied.
⁴⁾ appropriate connector cable: BIS C-505-PU-__ / BIS C-506-PU-__ / BIS C-517-PVC-__ / BIS C-518-PVC-__
 For details, see ordering information for cable and connectors
⁵⁾ only with BIS C-520-PVC-05 with 5-pin connector
⁶⁾ only with BIS C-516-PU-__ with 8-pin connector

Selection Criteria Read/Write Heads Series BIS C-3_ _

Distance between neighboring Data Carrier

Data Carrier Type	Minimal Distance [mm] for		Data Carrier Type	Minimal Distance [mm] for	
	static Mode V = 0 m/min	dynamic Mode V > 0 m/min		static Mode V = 0 m/min	dynamic Mode V > 0 m/min
BIS C-100.../A	32	$V_{dyn} + 37$	BIS C-126.../L	120	$V_{dyn} + 125$
BIS C-103.../A	32	$V_{dyn} + 37$	BIS C-127.../L	340	$V_{dyn} + 345$
BIS C-104.../A	60	$V_{dyn} + 65$	BIS C-128.../L	120	$V_{dyn} + 125$
BIS C-105.../A	32	$V_{dyn} + 37$	BIS C-130.../L	64	$V_{dyn} + 69$
BIS C-108.../L	120	$V_{dyn} + 125$	BIS C-130-05/L-SA1	64	$V_{dyn} + 69$
BIS C-108.../L-SA2	120	$V_{dyn} + 125$	BIS C-130-05/L-SA2	64	$V_{dyn} + 69$
BIS C-117.../A	60	$V_{dyn} + 65$	BIS C-133.../L	120	$V_{dyn} + 125$
BIS C-117.../L	120	$V_{dyn} + 125$	BIS C-150 with BIS C-351 or BIS C-653	270	$V_{dyn} + 275$
BIS C-121.../L	32	$V_{dyn} + 37$	BIS C-190.../L	120	$V_{dyn} + 125$
BIS C-121-04/L-SA1	32	$V_{dyn} + 37$	BIS C-191.../L	64	$V_{dyn} + 69$
BIS C-122.../L	32	$V_{dyn} + 37$			

The distance between two data carriers is defined as the free space between two data carriers of equal size. When the data carriers differ in size or when the read/write head is larger the distance of the larger device has to be applied.
For dynamic mode V has to be in [m/min].
For distances between read/write heads see previous page.

Installation in Aluminum

With Clear Zone, Static Operation

When installing the components in aluminum, provide clear zones for fault-free operation.

In static operation the depth of the clear zone in aluminum must be kept to at least 10 mm.
Fig. 1

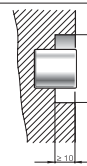

Fig. 1

The clear zone dimension **A** corresponds to 2x the diameter of the larger communication partner plus 1x the diameter of the smaller communication partner (see specification for read/write head).
Fig. 2

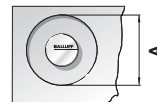

Fig. 2

In combination with read/write heads BIS C-318, 327, 328, 350, 351 and 355 the dimensions **B** and **C** are calculated using the length and width of the larger communication partner (data carrier or read/write head) plus the maximum possible offset (see specification for read/write head).
Fig. 3

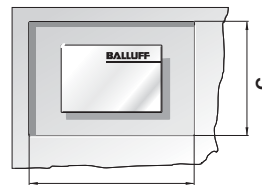

Fig. 3

Installation in Aluminium

With Clear Zone, Dynamic Operation

In dynamic mode the depth of the clear zone in aluminum must also be at least 10 mm. Fig. 1

The clear zone dimension **A** corresponds to 2x the diameter of the larger communication partner plus 1x the diameter of the smaller communication partner. The clear zone dimension **C** corresponds to the diameter of the larger communication partner plus the corresponding maximum offset (see specification for read/write head). Fig. 4

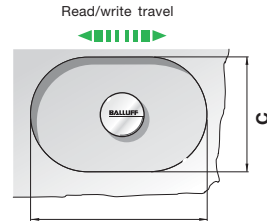

Fig. 4

In combination with read/write heads BIS C-318, 327, 328, 350, 351 and 355, dimension **B** is calculated as 2x the read/write travel (see specification for read/write heads) plus the width of the data carrier. The clear zone dimension **C** corresponds to the read/write head length plus the corresponding maximum offset (see specification for read/write head). Fig. 5

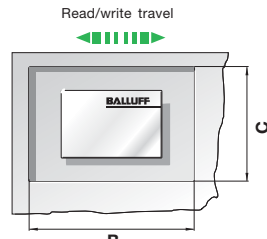
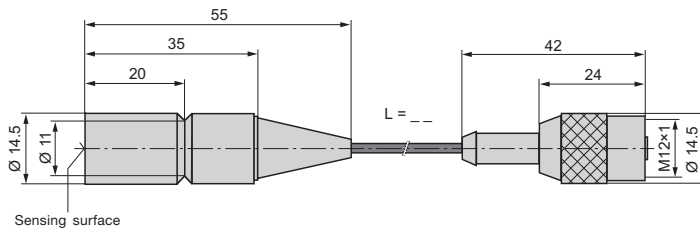

Fig. 5

Read/Write Head BIS C-300-__

Dimensions
Standard:
Length __
01 = 1 m
05 = 5 m
10 = 10 m



Distances and Velocities between Read/Write Head and matching Data Carrier

Matching Data Carrier	Distance [mm]		Static Mode (V = 0)						Dynamic Mode (V > 0)		
	Read	Write	Offset [mm] at a distance [mm] of						Distance [mm]	Vmax. [m/min] ¹⁾	
			0.7	1	3	5	7	10		Read	Write
for flush mounting in steel	BIS C-100-05/A ²⁾	0 to 4	0 to 4	± 3	± 2				1	8	
	BIS C-103-05/A ²⁾	0 to 3.5	0 to 3.5	± 3	± 2				1	6	
	BIS C-105-05/A ²⁾	0 to 3.5	0 to 3.5	± 3	± 2				1	6	
	BIS C-121-04/L	0 to 2	0 to 2	± 2					1	6	
	BIS C-121-04/L-SA1	0 to 1.2	0 to 1.2	± 2							
	BIS C-122-04/L	0 to 2.5	0 to 2.5	± 2.5					1	6	
	BIS C-130-05/L	0 to 4	0 to 4	± 3.5	± 3				1 to 3	7	
non-flush	BIS C-130-05/L	0 to 4	0 to 4	± 5	± 3				1 to 3	10 to 8	7 to 5
	BIS C-130-05/L-SA1	0 to 4	0 to 4	± 5	± 4				1 to 3	10 to 8	7 to 5
	BIS C-130-05/L-SA2	0 to 3.2	0 to 3.2	± 4	± 3				1 to 2	8 to 7	5 to 4
	BIS C-191-__/L	0 to 3.5	0 to 3.5	± 4	± 3				1 to 3	10 to 7	6 to 4

¹⁾ The indicated relative speeds assume a read or write of the first 4 bytes of the data carrier (bytes 0...3).
²⁾ This data carrier is appropriate for installation in aluminum. Dynamic operation not permitted!

**Read/Write Head
BIS C-306-__**

Dimensions
Standard:
Length __
01 = 1 m
05 = 5 m
10 = 10 m

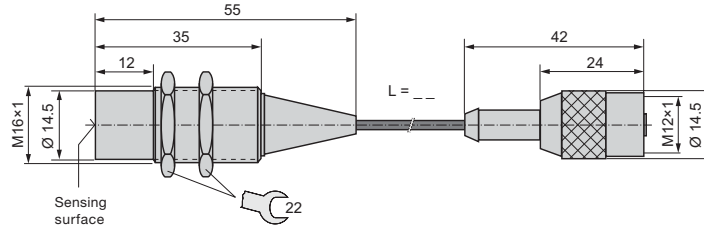

Distances and Velocities between Read/Write Head and matching Data Carrier

Matching Data Carrier	Distance [mm]		Static Mode (V = 0)						Dynamic Mode (V > 0)			
	Read	Write	Offset [mm] at a distance [mm] of						Distance [mm]	Vmax. [m/min] ¹⁾		
			0.7	1	3	5	7	10	Read	Write		
for flush mounting in steel	BIS C-100-05/A ²⁾	0 to 4	0 to 4	± 3 ± 2						1	8	
	BIS C-103-05/A ²⁾	0 to 3.5	0 to 3.5	± 3 ± 2						1	6	
	BIS C-105-05/A ²⁾	0 to 3.5	0 to 3.5	± 3 ± 2						1	6	
	BIS C-121-04/L	0 to 2	0 to 2	± 2						1	6	
	BIS C-121-04/L-SA1	0 to 1.2	0 to 1.2	± 2								
	BIS C-122-04/L	0 to 2.5	0 to 2.5	± 2.5						1	6	
	BIS C-130-05/L	0 to 4	0 to 4	± 3.5 ± 3						1 to 3	7	
non-flush	BIS C-130-05/L	0 to 4	0 to 4	± 5 ± 3						1 to 3	10 to 8 7 to 5	
	BIS C-130-05/L-SA1	0 to 4	0 to 4	± 5 ± 4						1 to 3	10 to 8 7 to 5	
	BIS C-130-05/L-SA2	0 to 3.2	0 to 3.2	± 4 ± 3						1 to 2	8 to 7 5 to 4	
	BIS C-191-__/L	0 to 3.5	0 to 3.5	± 4 ± 3						1 to 3	10 to 7 6 to 4	

¹⁾ The indicated relative speeds assume a read or write of the first 4 bytes of the data carrier (bytes 0...3).
²⁾ This data carrier is appropriate for installation in aluminum. Dynamic operation not permitted!

english

BALLUFF

**Read/Write Head
BIS C-302-__**

Dimensions
Standard:
Length __
05 = 5 m
10 = 10 m

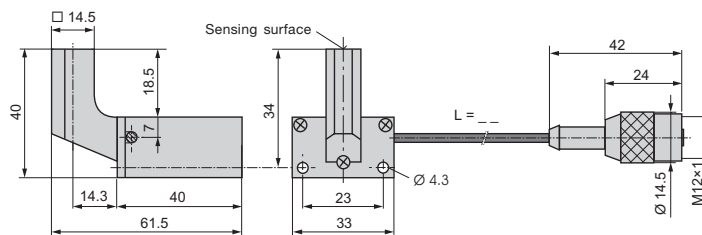

Distances and Velocities between Read/Write Head and matching Data Carrier

Matching Data Carrier	Distance [mm]		Static Mode (V = 0)						Dynamic Mode (V > 0)			
	Read	Write	Offset [mm] at a distance [mm] of						Distance [mm]	Vmax. [m/min] ¹⁾		
			0.7	1	3	5	7	10	Read	Write		
for flush mounting in steel	BIS C-100-05/A ²⁾	0 to 4	0 to 4	± 3 ± 2						1	8	
	BIS C-103-05/A ²⁾	0 to 3	0 to 3	± 3 ± 1.5						1	6	
	BIS C-105-05/A ²⁾	0 to 3	0 to 3	± 3 ± 1.5						1	6	
	BIS C-121-04/L	0 to 1.5	0 to 1.5	± 1.5						1	4	
	BIS C-121-04/L-SA1	0 to 0.7	0 to 0.7	± 1								
	BIS C-122-04/L	0 to 2	0 to 2	± 2						1	5	
	BIS C-130-05/L	0 to 3.5	0 to 3.5	± 3 ± 2						1 to 3	5	
non-flush	BIS C-130-05/L	0 to 4	0 to 4	± 5 ± 3						1 to 3	8 to 5 6 to 3	
	BIS C-130-05/L-SA1	0 to 4	0 to 4	± 5 ± 3						1 to 3	8 to 5 6 to 3	
	BIS C-130-05/L-SA2	0 to 3.2	0 to 3.2	± 4 ± 2						1 to 2	6 to 5 4 to 3	
	BIS C-191-__/L	0 to 3	0 to 3	± 4 ± 2						1 to 3	6 to 5 4 to 3	

¹⁾ The indicated relative speeds assume a read or write of the first 4 bytes of the data carrier (bytes 0...3).
²⁾ This data carrier is appropriate for installation in aluminum. Dynamic operation not permitted!

Read/Write Head BIS C-305-__

Dimensions
Standard:
Length __
01 = 1 m
05 = 5 m
10 = 10 m

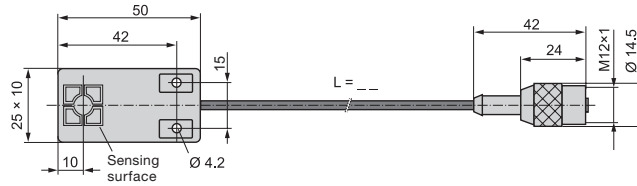

Distances and Velocities between Read/Write Head and matching Data Carrier

Matching Data Carrier	Distance [mm]		Static Mode (V = 0)					Dynamic Mode (V > 0)		
	Read	Write	Offset [mm] at a distance [mm] of					Distance [mm]	Vmax. [m/min] ¹⁾	
			0.7	1	3	5	7		10	Read
for flush mounting in steel										
BIS C-100-05/A ²⁾	0 to 4	0 to 4	± 3 ± 2					1	8	
BIS C-103-__/A ²⁾	0 to 5	0 to 5	± 4 ± 3					1	10	
BIS C-105-__/A ²⁾	0 to 5	0 to 5	± 4 ± 3					1	10	
BIS C-117-05/A ²⁾	1 to 8	1 to 8	± 5 ± 4 ± 3					1 to 5	12 to 7	7 to 4
BIS C-121-04/L	0 to 2	0 to 2	± 2					1	6	
BIS C-121-04/L-SA1	0 to 1.2	0 to 1.2	± 2							
BIS C-122-04/L	0 to 2.5	0 to 2.5	± 3 ± 2					1	8	
non-flush										
BIS C-108-__/L	0 to 6	0 to 6	± 8 ± 7 ± 5					1 to 5	20 to 12	12 to 7
BIS C-108-__/L-SA2	0 to 6	0 to 6	± 8 ± 7 ± 5					1 to 5	20 to 12	12 to 7
BIS C-117-05/L	0 to 7	0 to 7	± 8.5 ± 7.5 ± 6 ± 4					1 to 5	21 to 16	12 to 9
BIS C-117-05/A	0 to 10	0 to 10	± 6 ± 6 ± 6 ± 5 ± 3					2 to 8	16 to 13	9 to 7
BIS C-128-05/L	0 to 6	0 to 6	± 8 ± 7 ± 5					1 to 5	20 to 12	12 to 7
BIS C-130-05/L	0 to 7	0 to 7	± 5 ± 5 ± 4 ± 2					1 to 6	14 to 11	11 to 6
BIS C-130-05/L-SA1	0 to 7	0 to 7	± 5 ± 5 ± 4 ± 2					1 to 6	14 to 11	11 to 6
BIS C-130-05/L-SA2	0 to 6.2	0 to 6.2	± 5 ± 5 ± 4					1 to 5	14 to 11	11 to 6

¹⁾ The indicated relative speeds assume a read or write of the first 4 bytes of the data carrier (bytes 0...3).
²⁾ This data carrier is appropriate for installation in aluminum. Dynamic operation not permitted!

Read/Write Head BIS C-319-__

Dimensions
Standard:
Length __
01 = 1 m
05 = 5 m
10 = 10 m

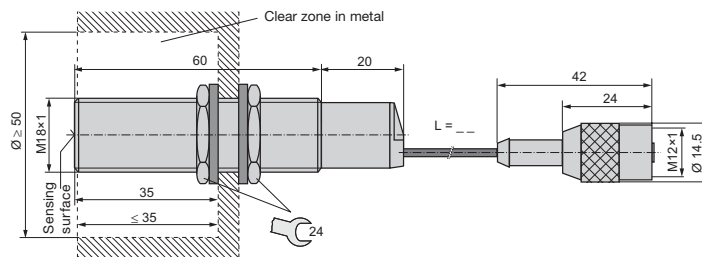

Distances and Velocities between Read/Write Head and matching Data Carrier

Matching Data Carrier	Distance [mm]		Static Mode (V = 0)					Dynamic Mode (V > 0)		
	Read	Write	Offset [mm] at a distance [mm] of					Distance [mm]	Vmax. [m/min] ¹⁾	
			1	3	5	7	10		Read	Write
non-flush										
BIS C-108-__/L	0 to 14	0 to 14	± 12 ± 12 ± 11 ± 11 ± 9					0 to 10	26 to 20	17 to 13
BIS C-117-05/L	0 to 15	0 to 15	± 13 ± 12 ± 12 ± 11 ± 10					0 to 10	31 to 22	18 to 15
BIS C-130-05/L	0 to 13	0 to 13	± 9 ± 9 ± 9 ± 8.5 ± 7.5					0 to 10	23 to 19	13 to 11
BIS C-130-05/L-SA1	0 to 13	0 to 13	± 9 ± 9 ± 9 ± 8.5 ± 7.5					0 to 10	23 to 19	13 to 11
BIS C-130-05/L-SA2	0 to 12	0 to 12	± 9 ± 9 ± 9 ± 8 ± 6					0 to 9	23 to 19	13 to 11
BIS C-191-__/L	0 to 11	0 to 11	± 9 ± 9 ± 9 ± 8					0 to 8	22 to 20	13 to 11

¹⁾ The indicated relative speeds assume a read or write of the first 4 bytes of the data carrier (bytes 0...3).

Read/Write Head BIS C-326-__

Dimensions
Standard:
Length __
05 = 5 m
10 = 10 m

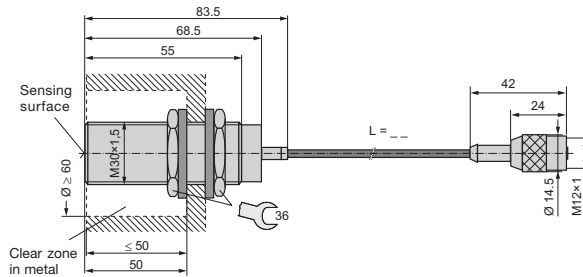

Distances and Velocities between Read/Write Head and matching Data Carrier

Matching Data Carrier	Static Mode (V = 0)						Dynamic Mode (V > 0)				
	Distance [mm]		Offset [mm] at a distance [mm] of						Distance [mm]	Vmax. [m/min] ¹⁾	
	Read	Write	0.7	1	3	5	7	10	Read	Write	
non-flush	BIS C-117-05/L	0 to 18	0 to 18	± 15	± 15	± 15	± 14	± 11	0 to 15	28 to 23	22 to 16
	BIS C-128-_/L	0 to 15	0 to 15	± 14	± 14	± 14	± 14	± 8.5	0 to 10	34 to 21	19 to 12
	BIS C-130-05/L	0 to 13	0 to 13	± 12	± 12	± 10	± 10		0 to 10	30 to 19	17 to 11
	BIS C-130-05/L-SA1	0 to 13	0 to 13	± 12	± 12	± 10	± 10		0 to 10	30 to 19	17 to 11
	BIS C-130-05/L-SA2	0 to 12	0 to 12	± 12	± 12	± 10	± 10		0 to 10	30 to 19	17 to 11
	BIS C-133-_/L	0 to 12	0 to 12	± 14	± 14	± 14	± 8.5		0 to 10	34 to 21	19 to 12
	BIS C-190-_/L	0 to 18	0 to 18	± 17	± 17	± 17	± 16	± 14	0 to 15	43 to 29	25 to 17
on steel	BIS C-128-_/L	0 to 12.5	0 to 12.5	± 13	± 12	± 12	± 11	± 8	0 to 10	32 to 19	28 to 11

¹⁾ The indicated relative speeds assume a read or write of the first 4 bytes of the data carrier (bytes 0...3).

Read/Write Head BIS C-315-__

Dimensions
Standard:
Length __
01 = 1 m
05 = 5 m
10 = 10 m

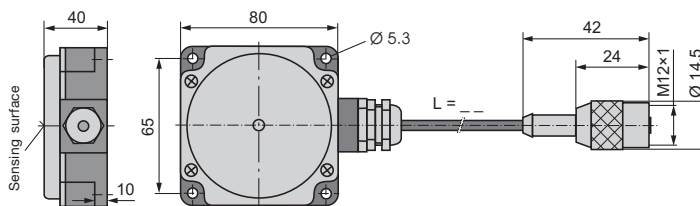

Distances and Velocities between Read/Write Head and matching Data Carrier

Matching Data Carrier	Distance [mm]		Static Mode (V = 0)								Dynamic Mode (V > 0)		
	Read	Write	Offset [mm] at a distance [mm] of								Distance [mm]	Vmax. [m/min] ¹⁾	
			1	3	5	7	10	15	20	Read	Write		
flush ²⁾	BIS C-104-_/A	1 to 13	1 to 13	± 15	± 14	± 11	± 10	± 8		1 to 7	25 to 13	18 to 9	
	BIS C-117-05/A	0 to 15	0 to 15	± 15	± 15	± 14	± 12	± 12		3 to 10	34 to 25	28 to 14	
non-flush	BIS C-108-_/L	2 to 16	2 to 16	± 15	± 14	± 12	± 11	± 8		2 to 10	25 to 13	18 to 9	
	BIS C-108-_/L-SA2	2 to 16	2 to 16	± 15	± 15	± 12	± 10	± 8		2 to 10	25 to 13	18 to 9	
	BIS C-117-05/L	0 to 20	0 to 20	± 17	± 17	± 17	± 15	± 15	± 14	1 to 15	42 to 33	24 to 19	
	BIS C-127-05/L	10 to 30	10 to 30	± 30	± 30	± 30	± 30	± 27	± 20	10 to 20	68	39	
	BIS C-128-_/L	0 to 18	0 to 18	± 17	± 17	± 17	± 15	± 15	± 14	1 to 15	42 to 23	24 to 19	
	BIS C-130-05/L	0 to 18	0 to 18	± 16	± 16	± 16	± 14	± 14	± 11	1 to 15	39 to 27	22 to 15	
	BIS C-133-_/L	0 to 15	0 to 15	± 17	± 15	± 15	± 14	± 14		1 to 10	42 to 33	24 to 19	
	BIS C-190-_/L	0 to 20	0 to 20	± 18	± 18	± 18	± 18	± 18	± 16	1 to 15	44 to 39	25 to 23	

¹⁾ The indicated relative speeds assume a read or write of the first 4 bytes of the data carrier (bytes 0...3).
²⁾ For flush mounting in steel.

Read/Write Head BIS C-310-__

Dimensions
Standard:
Length __
01 = 1 m
05 = 5 m
10 = 10 m

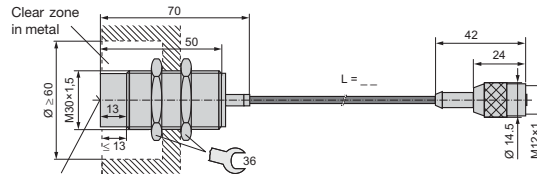

Distances and Velocities between Read/Write Head and matching Data Carrier

Matching Data Carrier	Distance [mm]		Static Mode (V = 0)						Dynamic Mode (V > 0)		
	Read	Write	Offset [mm] at a distance [mm] of						Distance [mm]	Vmax. [m/min] ¹⁾	
for flush moun- ting in steel	BIS C-104-_/A ²⁾	1 to 11	1 to 11	$\pm 7.5 \pm 7 \pm 7 \pm 7$						3 to 7	17 10
	BIS C-117-05/A ²⁾	1 to 12	1 to 12	$\pm 7.5 \pm 7.5 \pm 7 \pm 6.5$						3 to 7	17 to 16 13
	BIS C-128-_/L	0 to 8	0 to 8	$\pm 8 \pm 7 \pm 6.5 \pm 5.5$						1 to 5	19 to 16 11 to 9
non- flush	BIS C-130-05/L-SA1	0 to 8	0 to 8	$\pm 6.5 \pm 6 \pm 5.5$						1 to 5	16 to 14 9 to 8
	BIS C-104-_/A	0 to 12	0 to 12	$\pm 7.5 \pm 7 \pm 7 \pm 7$						3 to 7	17 10
	BIS C-108-_/L	0 to 12	0 to 12	$\pm 10 \pm 9 \pm 9 \pm 8.5$						1 to 7	24 to 22 14 to 12
	BIS C-108-_/L-SA2	0 to 11	0 to 11	$\pm 10 \pm 9 \pm 8.5 \pm 7.5$						1 to 7	24 to 17 14 to 10
	BIS C-117-05/L	0 to 13	0 to 13	$\pm 11 \pm 10 \pm 10 \pm 9.5$						1 to 7	27 to 24 15 to 14
	BIS C-128-_/L	0 to 13	0 to 13	$\pm 10 \pm 10 \pm 9 \pm 9$						1 to 7	24 to 22 14 to 11
	BIS C-130-05/L	0 to 11	0 to 11	$\pm 9 \pm 8 \pm 7 \pm 5$						1 to 7	23 to 12 13 to 7
	BIS C-130-05/L-SA2	0 to 10	0 to 10	$\pm 9 \pm 8 \pm 7 \pm 4$						1 to 7	23 to 10 13 to 5
	BIS C-133-_/L	0 to 10	0 to 10	$\pm 10 \pm 9 \pm 9 \pm 7$						1 to 7	24 to 17 14 to 10
	BIS C-190-_/L	0 to 11	0 to 11	$\pm 10 \pm 9 \pm 9 \pm 8 \pm 6.5$						1 to 10	25 to 16 14 to 9
	BIS C-191-_/L	0 to 10	0 to 10	$\pm 8 \pm 7.5 \pm 7 \pm 6.5$						1 to 7	20 to 16 11 to 9

¹⁾ The indicated relative speeds assume a read or write of the first 4 bytes of the data carrier (bytes 0...3).

²⁾ This data carrier is appropriate for installation in aluminum. Dynamic operation not permitted!

english

BALLUFF

Read/Write Head BIS C-319/__-S4

Dimensions
Standard:
Length __
01 = 1 m
05 = 5 m
10 = 10 m
Compatible
connection cable ²⁾

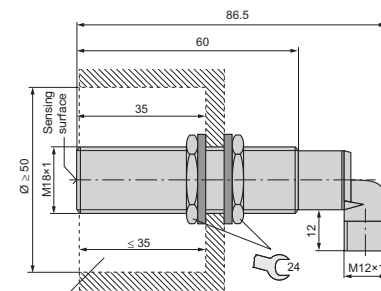

Distances and Velocities between Read/Write Head and matching Data Carrier

Matching Data Carrier	Distance [mm]		Static Mode (V = 0)						Dynamic Mode (V > 0)		
	Read	Write	Offset [mm] at a distance [mm] of						Distance [mm]	Vmax. [m/min] ¹⁾	
non- flush	BIS C-108-_/L	0 to 14	0 to 14	$\pm 12 \pm 12 \pm 11 \pm 11 \pm 9$						0 to 10	26 to 20 17 to 13
	BIS C-117-05/L	0 to 15	0 to 15	$\pm 13 \pm 12 \pm 12 \pm 11 \pm 10$						0 to 10	31 to 22 18 to 15
	BIS C-130-05/L	0 to 13	0 to 13	$\pm 9 \pm 9 \pm 9 \pm 8.5 \pm 7.5$						0 to 10	23 to 19 13 to 11
	BIS C-130-05/L-SA1	0 to 13	0 to 13	$\pm 9 \pm 9 \pm 9 \pm 8.5 \pm 7.5$						0 to 10	23 to 19 13 to 11
	BIS C-130-05/L-SA2	0 to 12	0 to 12	$\pm 9 \pm 9 \pm 9 \pm 8 \pm 6$						0 to 9	23 to 19 13 to 11
	BIS C-190-_/L	0 to 11	0 to 11	$\pm 9 \pm 9 \pm 9 \pm 8$						0 to 8	22 to 20 13 to 11

¹⁾ The indicated relative speeds assume a read or write of the first 4 bytes of the data carrier (bytes 0...3).

²⁾ BIS C-505-PU-_/ / BIS C_506-PU-_/ / BIS C-517-PVC-_/ / BIS C-518-PVC-_/

Read/Write Head BIS C-315/_-S4

Dimensions
Standard:
Length __
05 = 5 m
10 = 10 m
Compatible
connection cable ³⁾

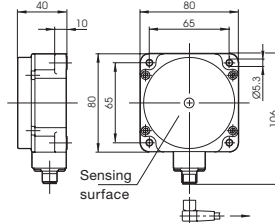

**Distances and
Velocities between
Read/Write Head
and matching
Data Carrier**

Matching Data Carrier	Static Mode (V = 0)							Dynamic Mode (V > 0)			
	Distance [mm]		Offset [mm] at a distance [mm] of					Distance [mm]	Vmax. [m/min] ¹⁾		
	Read	Write	1	3	5	7	10		15	20	Read
flush ²⁾	BIS C-104-_-/A	1 to 13	1 to 13	± 15	± 14	± 11	± 10	± 8	1 to 7	25 to 13	18 to 9
	BIS C-117-05/A	0 to 15	0 to 15	± 15	± 13	± 14	± 12	± 12	3 to 10	34 to 25	20 to 14
non-flush	BIS C-108-_-/L	2 to 16	2 to 16	± 15	± 14	± 12	± 11	± 8	2 to 10	25 to 13	18 to 9
	BIS C-108-_-/L-SA2	2 to 16	2 to 16	± 15	± 15	± 12	± 10	± 8	2 to 10	25 to 13	18 to 9
	BIS C-117-05/L	0 to 20	0 to 20	± 17	± 17	± 17	± 15	± 15 ± 14	1 to 15	42 to 33	24 to 19
	BIS C-127-05/L	10 to 30	10 to 30	± 30	± 30	± 30	± 30	± 30 ± 27 ± 20	10 to 20	39	68
	BIS C-128-_-/L	0 to 18	0 to 18	± 17	± 17	± 17	± 15	± 15 ± 14	1 to 15	42 to 33	24 to 19
	BIS C-130-05/L	0 to 18	0 to 18	± 16	± 16	± 16	± 14	± 14 ± 11	1 to 15	39 to 27	22 to 15
	BIS C-133-_-/L	0 to 15	0 to 15	± 17	± 15	± 15	± 14	± 14	1 to 10	42 to 33	24 to 19
	BIS C-190-_-/L	0 to 20	0 to 20	± 18	± 18	± 18	± 18	± 18 ± 16	1 to 15	44 to 39	25 to 23

¹⁾ The indicated relative speeds assume a read or write of the first 4 bytes of the data carrier (bytes 0...3).
²⁾ For flush mounting in steel.
³⁾ BIS C-505-PU-_- / BIS C_506-PU-_- / BIS C-517-PVC-_- / BIS C-518-PVC-_-

Read/Write Head BIS C-323/_-S4

Dimensions
Standard:
Length __
05 = 5 m
10 = 10 m
Compatible
connection cable ¹⁾

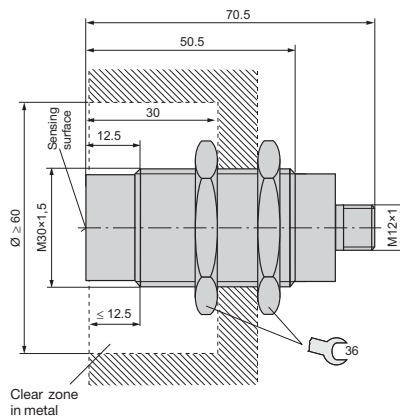

¹⁾ BIS C-505-PU-_- / BIS C_506-PU-_- / BIS C-517-PVC-_- / BIS C-518-PVC-_-

Distances and velocities between read/write head and matching data carrier see the following [7].

Read/Write Head BIS C-323/_-S4 (continued)

Distances and Velocities between Read/Write Head and matching Data carrier

Matching Data Carrier	Distance [mm]		Static Mode (V = 0)						Dynamic Mode (V > 0)		
	Read	Write	Offset [mm] at a distance [mm] of						Distance [mm]	Vmax. [m/min] ¹⁾	
			1	3	5	7	10	15		Read	Write
for flush moun-	BIS C-104-_/A	1 to 11	1 to 11	± 7.5	± 7	± 7	± 7	± 7	3 to 7	17	10
ing in	BIS C-117-05/A	1 to 12	1 to 12	± 7.5	± 7.5	± 7	± 6.5		3 to 7	17 to 16	13
steel	BIS C-128-_/L	0 to 8	0 to 8	± 8	± 7	± 6.5	± 5.5		1 to 5	19 to 16	11 to 9
non-flush	BIS C-130-04/L-SA1	0 to 8	0 to 8	± 6.5	± 6	± 5.5			1 to 5	16 to 14	9 to 8
	BIS C-104-_/A	0 to 12	0 to 12	± 7.5	± 7	± 7	± 7		3 to 7	17	10
	BIS C-108-_/L	0 to 12	0 to 12	± 10	± 9	± 9	± 8.5		1 to 7	24 to 22	14 to 12
	BIS C-108-_/L-SA2	0 to 11	0 to 11	± 10	± 9	± 8.5	± 7.5		1 to 7	24 to 17	16 to 10
	BIS C-117-05/L	0 to 13	0 to 13	± 11	± 10	± 10	± 9.5		1 to 7	27 to 24	15 to 14
	BIS C-128-_/L	0 to 13	0 to 13	± 10	± 10	± 9	± 9		1 to 7	24 to 22	14 to 12
	BIS C-130-05/L	0 to 11	0 to 11	± 9	± 8	± 7	± 5		1 to 7	23 to 12	13 to 7
	BIS C-130-05/L-SA2	0 to 10	0 to 10	± 7	± 8	± 7	± 4		1 to 7	23 to 10	13 to 5
	BIS C-133-_/L	0 to 10	0 to 10	± 10	± 9	± 9	± 7		1 to 7	24 to 17	14 to 10
	BIS C-190-_/L	1 to 11	1 to 11	± 10	± 9	± 9	± 8	± 6.5	1 to 10	25 to 16	14 to 9
	BIS C-191-_/L	1 to 10	1 to 10	± 8	± 7.5	± 7	± 6.5		1 to 7	20 to 16	11 to 9

¹⁾ The indicated relative speeds assume a read or write of the first 4 bytes of the data carrier (bytes 0...3).

Read/Write Head BIS C-324/_-S4

Dimensions
Standard:
Length __
05 = 5 m
10 = 10 m
Compatible connection cable ¹⁾

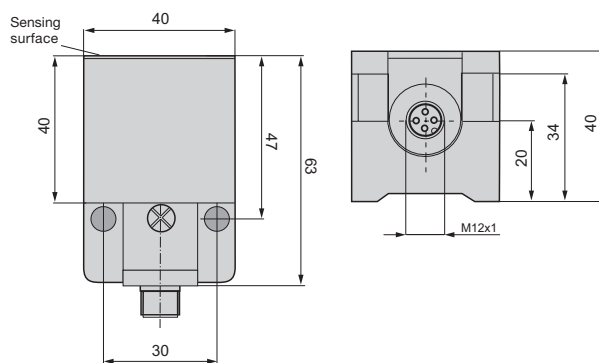

¹⁾ BIS C-505-PU-_/ / BIS C_506-PU-_/ / BIS C-517-PVC-_/ / BIS C-518-PVC-_/

Distances and velocities between read/write head and matching data carrier see the following []

Read/Write Head
BIS C-324/_ _-S4 (continued)

Distances and Velocities between Read/Write Head and matching Data carrier

Matching Data Carrier	Distance [mm]		Static Mode (V = 0)						Dynamic Mode (V > 0)		
	Read	Write	Offset [mm] at a distance [mm] of						Distance [mm]	Vmax. [m/min] ¹⁾	
			1	3	5	7	10	15		Read	Write
flush	BIS C-104-_/A	1 to 11	1 to 11	± 7.5	± 7	± 7	± 7		3 to 7	17	10
	BIS C-117-05/A	1 to 12	1 to 12	± 7.5	± 7.5	± 7	± 6.5		3 to 7	17 to 16	13
	BIS C-128-_/L	0 to 8	0 to 8	± 8	± 7	± 6.5	± 5.5		1 to 5	19 to 16	11 to 9
non flush	BIS C-130-05/L-SA1	0 to 8	0 to 8	± 6.5	± 6	± 5.5			1 to 5	16 to 14	9 to 8
	BIS C-104-_/A	0 to 12	0 to 12	± 7.5	± 7	± 7	± 7		3 to 7	17	10
	BIS C-108-_/L	0 to 12	0 to 12	± 10	± 9	± 9	± 8.5		1 to 7	24 to 22	14 to 12
	BIS C-108-_/L-SA2	0 to 11	0 to 11	± 10	± 9	± 8.5	± 7.5		1 to 7	24 to 17	14 to 10
	BIS C-117-05/L	0 to 13	0 to 13	± 11	± 10	± 10	± 9.5		1 to 7	27 to 24	15 to 14
	BIS C-128-_/L	0 to 13	0 to 13	± 10	± 10	± 9	± 9		1 to 7	24 to 22	14 to 12
	BIS C-130-05/L	0 to 11	0 to 11	± 9	± 8	± 7	± 5		1 to 7	23 to 12	13 to 7
	BIS C-130-05/L-SA2	0 to 10	0 to 10	± 9	± 8	± 7	± 4		1 to 7	23 to 10	13 to 5
	BIS C-133-_/L	0 to 10	0 to 10	± 10	± 9	± 9	± 7		1 to 7	24 to 17	14 to 10
	BIS C-190-_/L	0 to 11	0 to 11	± 10	± 9	± 8	± 8 ± 6.5		1 to 10	25 to 16	14 to 9
BIS C-191-_/L	0 to 10	0 to 10	± 8	± 7.5	± 7	± 6.5		1 to 7	20 to 16	11 to 9	

¹⁾ The indicated relative speeds assume a read or write of the first 4 bytes of the data carrier (bytes 0...3).

Read/Write Head
BIS C-325/_ _-S4

Dimensions

Standard:

Length _ _

01 = 1 m

05 = 5 m

10 = 10 m

Compatible

connection cable ²⁾

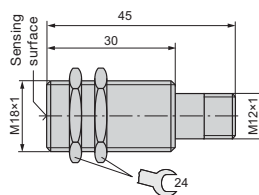

Distances and Velocities between Read/Write Head and matching Data carrier

Matching Data Carrier	Distance [mm]		Static Mode (V = 0)					Dynamic Mode (V > 0)		
	Read	Write	Offset [mm] at a distance [mm] of					Distance [mm]	Vmax. [m/min] ¹⁾	
			0.7	1	3	5	7		10	Read
flush ³⁾	BIS C-100-05/A	0 to 4	0 to 4	± 3.5	± 3			1	9	5
	BIS C-122-_/L	0 to 2.5	0 to 2.5	± 2.5				1	6	4
	BIS C-121-04/L-SA1	0 to 1.7	0 to 1.7	± 2	± 2					
non-flush	BIS C-130-05/L	0 to 4	0 to 4	± 4	± 2			0 to 5	6 to 3	4 to 2
	BIS C-130-05/L-SA1	0 to 3	0 to 3	± 4	± 2			0 to 5	6 to 3	4 to 2
	BIS C-130-05/L-SA2	0 to 3.5	0 to 3	± 4	± 3			1	6	4
	BIS C-191-_/L	0 to 2.5	0 to 2.5	± 4	± 3			1	6	4

¹⁾ The indicated relative speeds assume a read or write of the first 4 bytes of the data carrier (bytes 0...3).

²⁾ BIS C-505-PU-_/ / BIS C-506-PU-_/ / BIS C-517-PVC-_/ / BIS C-518-PVC-_/

³⁾ For flush mounting in steel.

Read/Write Head BIS C-328/_ _-S49

Dimensions
Standard:
Length _ _
01 = 1 m
05 = 5 m
10 = 10 m
Compatible
connection cable ²⁾

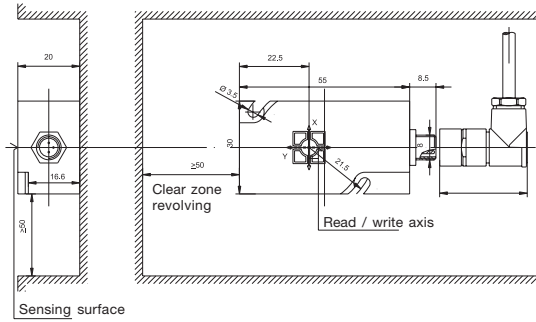

**Distances and
Velocities between
Read/Write Head
and matching
Data carrier**

Specifications by data carrier (non-flush)	Static Mode (V = 0)				Dynamic Mode (V > 0)	
	Distance [mm]		Offset to center axis at distance of		Distance [mm]	Vmax. [m/min] ¹⁾
	Read	Write	0 mm X / Y	3 mm X / Y	Read Y	Read Y
BIS C-122-04/L	0 to 3	0 to 3	±2.5 / ±12	±2.5 / ±12	1 to 3	30
BIS C-122-11/L	0 to 3	0 to 3	±2.5 / ±12	±2.5 / ±12	1 to 3	30

¹⁾ The indicated relative speeds assume a read or write of the first 6 bytes of the data carrier (bytes 0...5).
²⁾ BIS C-328/05_ _ / BIS C-523-PU_ _ / BIS C-523-PU1_ _

Read/Write Head BIS C-327-05

Dimensions

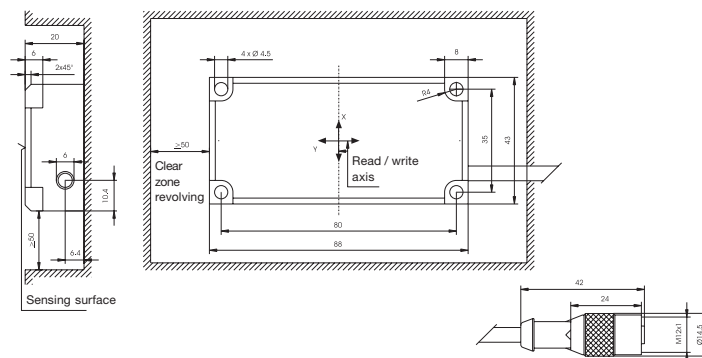

**Distances and
Velocities between
Read/Write Head
and matching
Data carrier**

Specifications by data carrier on steel	Static Mode (V = 0)				Dynamic Mode (V > 0)					
	Distance [mm]		Offset to center axis at distance of		Distance [mm]		Vmax. [m/min] ¹⁾			
	Read	Write	0 mm X / Y	2 mm X / Y	4 mm X / Y	6 mm X / Y	Read X	Write Y		
BIS C-128-05,11/L	0 to 8	0 to 8	±6 / ±30	±6 / ±30	±5 / ±27	±4 / ±25	1 to 6	1 to 6	8 to 5	40 to 35
BIS C-108-05,11,32/L	0 to 8	0 to 8	±6 / ±30	±6 / ±30	±5 / ±27	±4 / ±25	1 to 6	1 to 6	8 to 5	40 to 35
BIS C-190-05,11,32/L	0 to 8	0 to 8	±6 / ±30	±6 / ±30	±5 / ±27	±4 / ±25	1 to 6	1 to 6	8 to 5	40 to 35

¹⁾ The indicated relative speeds assume a read or write of the first 4 bytes of the data carrier (bytes 0...3).

Read/Write Head BIS C-318-__

Dimensions
Standard:
Length __
05 = 5 m
10 = 10 m

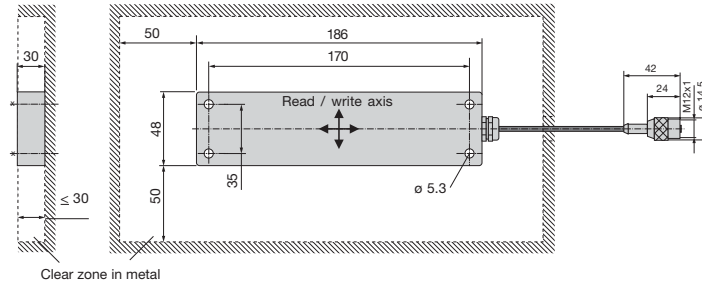

Distances and Velocities between Read/Write Head and matching Data carrier

Matching Data Carrier	Distance [mm]		Static Mode (V = 0)						Read-/Write range [mm]	Dynamic Mode (V > 0)		
	Read	Write	Offset [mm] at a distance [mm] of							Distance [mm]	Vmax. [m/min] ¹⁾	
			1	5	10	20	30	35			Read	Write
non-flush	BIS C-108-_/L-SA2	0 to 6	0 to 6	± 8.5	± 5.5				100	5	120	70
	BIS C-108-_/L	0 to 7	0 to 7	± 9.5	± 6.5				100	6	120	70
	BIS C-117-05/L	0 to 7	0 to 7	± 9.5	± 8.5				100	6	120	70
	BIS C-127-05/L	10 to 35	10 to 35			± 25	± 20		80	20	100	60
	BIS C-128-_/L	7.5	7.5	± 11	± 8				100	6	120	70
	BIS C-190-_/L	8	8	± 11	± 10				100	5	120	70

¹⁾ The indicated relative speeds assume a read or write of the first 4 bytes of the data carrier (bytes 0...3).

Read/Write Head BIS C-351-__

Dimensions
Standard:
Length __
05 = 5 m
10 = 10 m

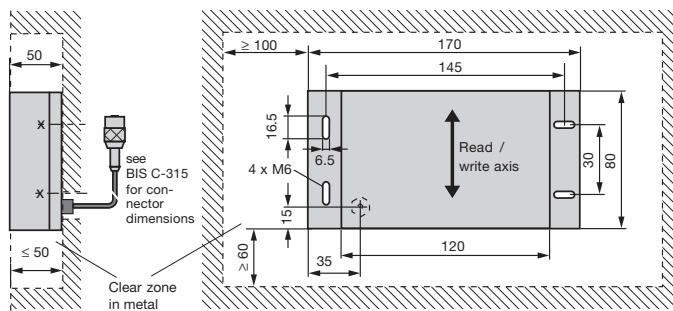

Distances and Velocities between Read/Write Head and matching Data carrier

Matching Data Carrier	Distance [mm]		Static Mode (V = 0)						Read-/Write range [mm]	Dynamic Mode (V > 0)		
	Read	Write	Offset [mm] at a distance [mm] of							Distance [mm]	Vmax. [m/min] ¹⁾	
			1	5	10	20	30	35			Read	Write
non-flush	BIS C-150-05/A	0 to 45	0 to 45			± 15	± 15		135 to 110	10 to 30	131 to 110	75 to 60
	BIS C-150-11/A	45	45			± 15	± 15		135 to 110	10 to 30	131 to 110	75 to 60
	BIS C-150-32/A	45	45			± 15	± 15		135 to 110	10 to 30	131 to 110	75 to 60

¹⁾ The indicated relative speeds assume a read or write of the first 4 bytes of the data carrier (bytes 0...3).

Read/Write Head BIS C-350-00,3

Dimensions
Standard:
Length
00,3 = 0.3 m
Compatible
connection cable ²⁾
for adapter BIS C-670

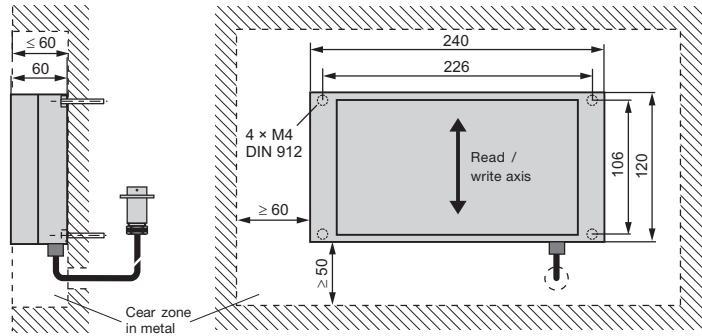

Distances and Velocities between Read/Write Head and matching Data carrier

Matching Data Carrier	Static Mode (V = 0)							Dynamic Mode (V > 0)				
	Distance [mm]		Offset [mm] at a distance [mm] of					Read-/Write range [mm]	Distance [mm]	Vmax. [m/min] ¹⁾		
	Read	Write	10	20	30	35	42			60	Read	Write
non-flush	BIS C-150-05/A	100	90	± 30	± 30			± 30	126/140	63/70	120	75
	BIS C-150-11/A	100	90	± 30	± 30			± 30	126/140	63/70	120	75
	BIS C-150-32/A	100	90	± 30	± 30			± 30	126/140	63/70	120	75

¹⁾ The indicated relative speeds assume a read or write of the first 4 bytes of the data carrier (bytes 0...3).
²⁾ BIS C-516-PU-__

Read/Write Head BIS C-355/05-S92

Dimensions
Standard:
Length
05 = 5 m
= Compatible
connection cable ²⁾
with 5 m length

For special requirements!
Using bar/double
antenna for increased
traverse speed

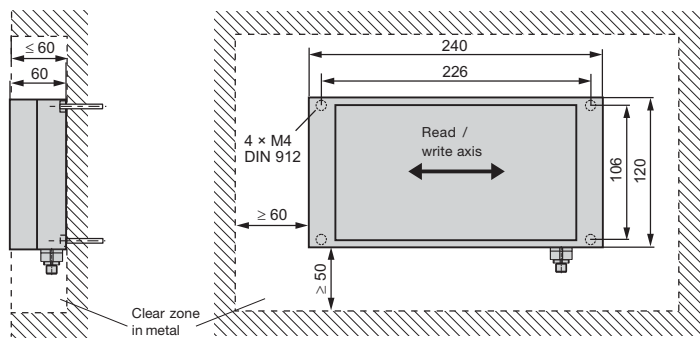

Distances and Velocities between Read/Write Head and matching Data carrier

Matching Data Carrier	Distance [mm]		Static Mode (V = 0)					Read-/Write range [mm]	Distance [mm]	Vmax. [m/min] ¹⁾			
	Read	Write	Offset [mm] at a distance [mm] of							Read	Write		
	0 to 40	0 to 35	10	20	30	35	42	260	1 to 35			220	150
non-flush	BIS C-150-05/A	0 to 40	0 to 35					± 15	± 5	260	1 to 35	220	150
	BIS C-150-11/A	0 to 40	0 to 35					± 15	± 5	260	1 to 35	220	150
	BIS C-150-32/A	0 to 40	0 to 35					± 15	± 5	260	1 to 35	220	150

¹⁾ The indicated relative speeds assume a read or write of the first 4 bytes of the data carrier (bytes 0...3).
²⁾ BIS C-520-PVC-05

Wiring Diagram

BIS C-300-__
 BIS C-302-__
 BIS C-305-__
 BIS C-306-__
 BIS C-310-__
 BIS C-315-__
 BIS C-318-__
 BIS C-319-__
 BIS C-326-__
 BIS C-351-__



Processor
 BIS C-60... or
 BIS C-600... with
 Adapter BIS C-650

BIS C-315/_-S4
 BIS C-319/_-S4
 BIS C-323/_-S4
 BIS C-324/_-S4
 BIS C-325/_-S4

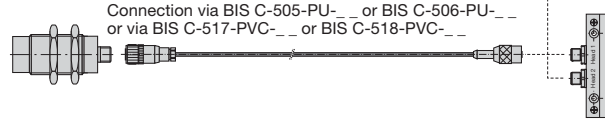

Processor
 BIS C-62... or
 BIS C-602... with
 Version 050

BIS C-350-00,3

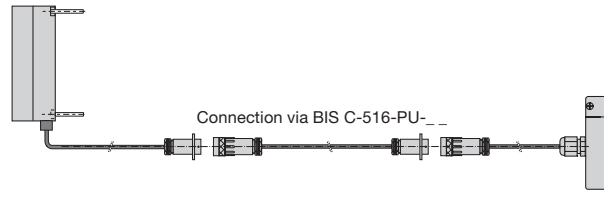

Processor
 BIS C-60... or
 BIS C-600... with
 Adapter BIS C-670

Connectors and cables:
 see ¶ 38 ff.

english

Connection Cable for Read/Write Heads with S4 Connectors

Connection cable
BIS C-518-PVC-__
 With straight M12 connector on both ends



Connection cable
BIS C-517-PVC-__
 With one straight and one right-angle M12 connector

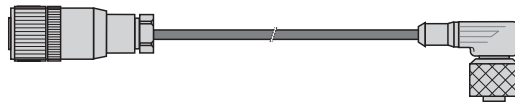

Connection cable
BIS C-506-PU-__
BIS C-506-PU1-__¹⁾
 With one straight and one right-angle M12 connector

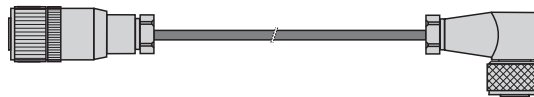

Connection cable
BIS C-505-PU-__
BIS C-505-PU1-__¹⁾
 With straight M12 connector on both ends



Pin	Wire color	Function
1	BU	AH
2	BN	EH
3	Shield	GND
4	--	n/c

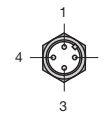

Ordering Code,
 Length __ :
 01 = 1 m
 05 = 5 m
 10 = 10 m

¹⁾ Drag-chain capable version

Additional Connection Cables for Read/Write Heads

Connection cable BIS C-512-PU-__¹⁾
 With 8-pin BKS S 45-00, connector and pigtail, for BIS C-35_ read/write heads or BIS C-901 converter to BIS C-480-...-E processor

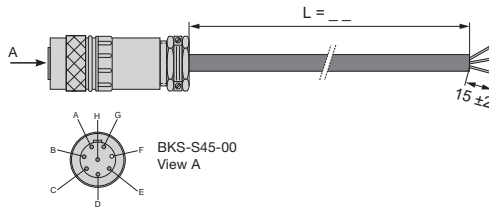

Pin	Function	Wire Color
A	+ 24 V	BN
B	0 V	BU
C	Shield	
D	+ S in	WH
E	- S in	GN
F	free	
G	+ S out	GY
H	- S out	PK

Connection cable BIS C-516-PU-__¹⁾
 With the 8-pin BKS S 45-00 and BKS S 46-00 connectors

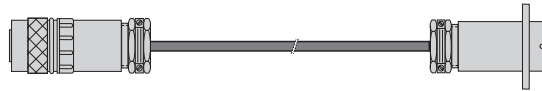

Connection cable BIS C-520-PVC-05
 With 5 m fixed length, for connecting BIS C-355/05-S92 read/write head to a processor using BIS C-654 adapter



¹⁾ Ordering code, cable length L = __: 05 = 5 m, 10 = 10 m ...
 The following lengths are available: up to 20 m: in 5 m increments,
 from 20 to 50 m: in 10 m increments and
 from 50 to 100 m: in 25 m increments.

Technical Information

CE Declaration of Conformity and user safety

CE This product was developed and produced considering the claimed European standards and guidelines.



You can separately request a Declaration of Conformity.
 Further safety measures you can find in chapter Safety (see ¶ 4).